

# GREENHOUSE

## ASSEMBLY INSTRUCTIONS

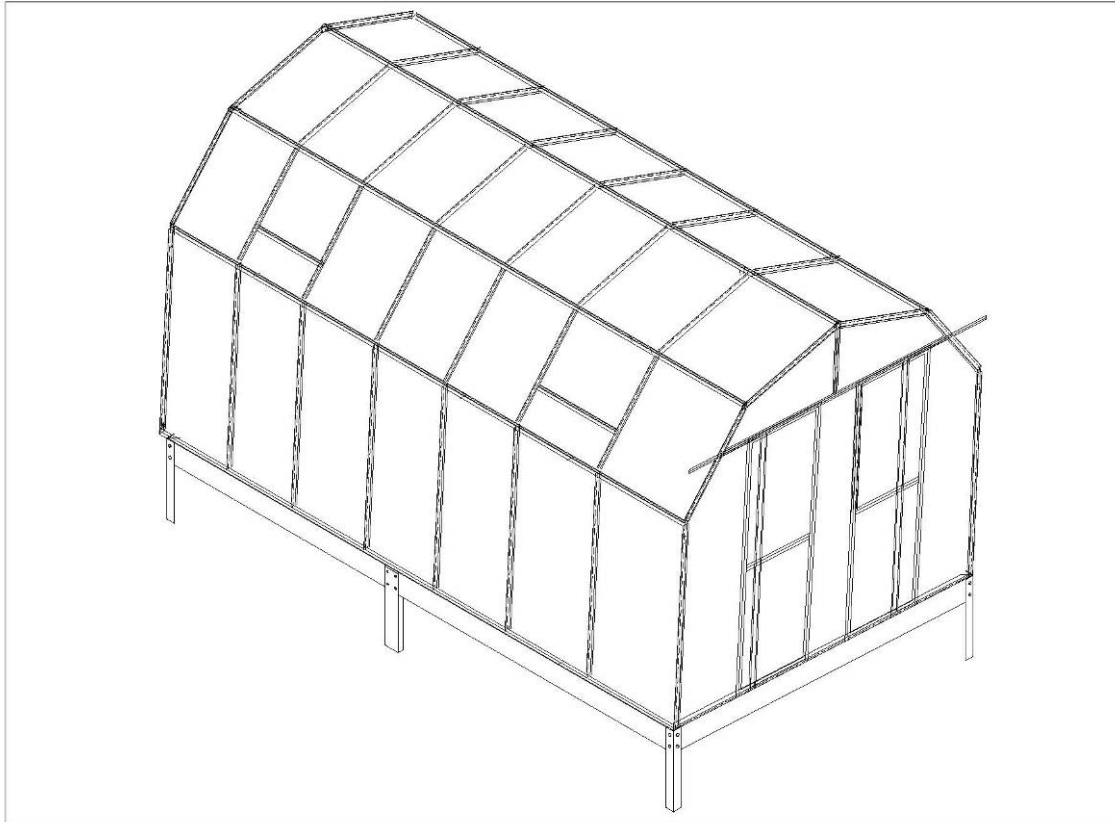

**Model number:RC801480-G**

Due to continuing improvements, actual product may differ slightly from the product described herein.

**TO PREVENT INJURY, READ AND UNDERSTAND THE ASSEMBLY INSTRUCTIONS BEFORE USE.**

### **NOTES**

1. It takes 2 people 6-8 hours to assemble.
2. Please note the assembly description of J06A/B/C.
3. The UV-protected side of the sheet is covered with transparent film and must face towards the sun.
4. Remove approximately 2 inches of film from all sheet edges before installing. Remove all film immediately after the construction is completed.
5. Make sure the greenhouse is located on a flat level surface.

## **GENERAL SAFETY WARNINGS AND PRECAUTIONS**

**KEEP WORKING AREA CLEAN AND DRY.** Cluttered, damp, or wet working areas invite injuries.

**STAY ALERT.** Watch what you are doing at all times. Use common sense. Do not use this product when you are tired or distracted from the job at hand. It is recommended to use glove for assembly.

**MAINTAIN THIS PRODUCT WITH CARE.** Keep this product clean and dry for better performance and longer life, and maintenance should be performed regularly.

**USE THE RIGHT PRODUCT FOR THE JOB.** Do not modify this product, and do not use this product for a purpose for which it was not intended.

**MAINTAIN A SAFE WORKING ENVIRONMENT.** Keep the working area well. Make sure there is adequate surrounding workspace. Avoid high traffic areas. Always keep the working area free of obstructions, grease, oil, trash, and other debris.

**PROPER GREENHOUSE LOCATION.** Make sure the greenhouse is located on a flat level surface.

**POLYCARBONATE PANEL NOTES.** Remove approximately 2 inches of film from all sheet edges before installing; And remove all film immediately after the construction is completed; The UV-protected side of the sheet is covered with transparent film and must face towards the sun.

**WARNING:** Please refer to other safety standards that are not covered in this manual for complete acknowledgement of safety issues.

# POLYCARBONATE PANEL DRAWING

Model number	RC801480-G
Specification	2440(W)*4270(L)*2440(H)

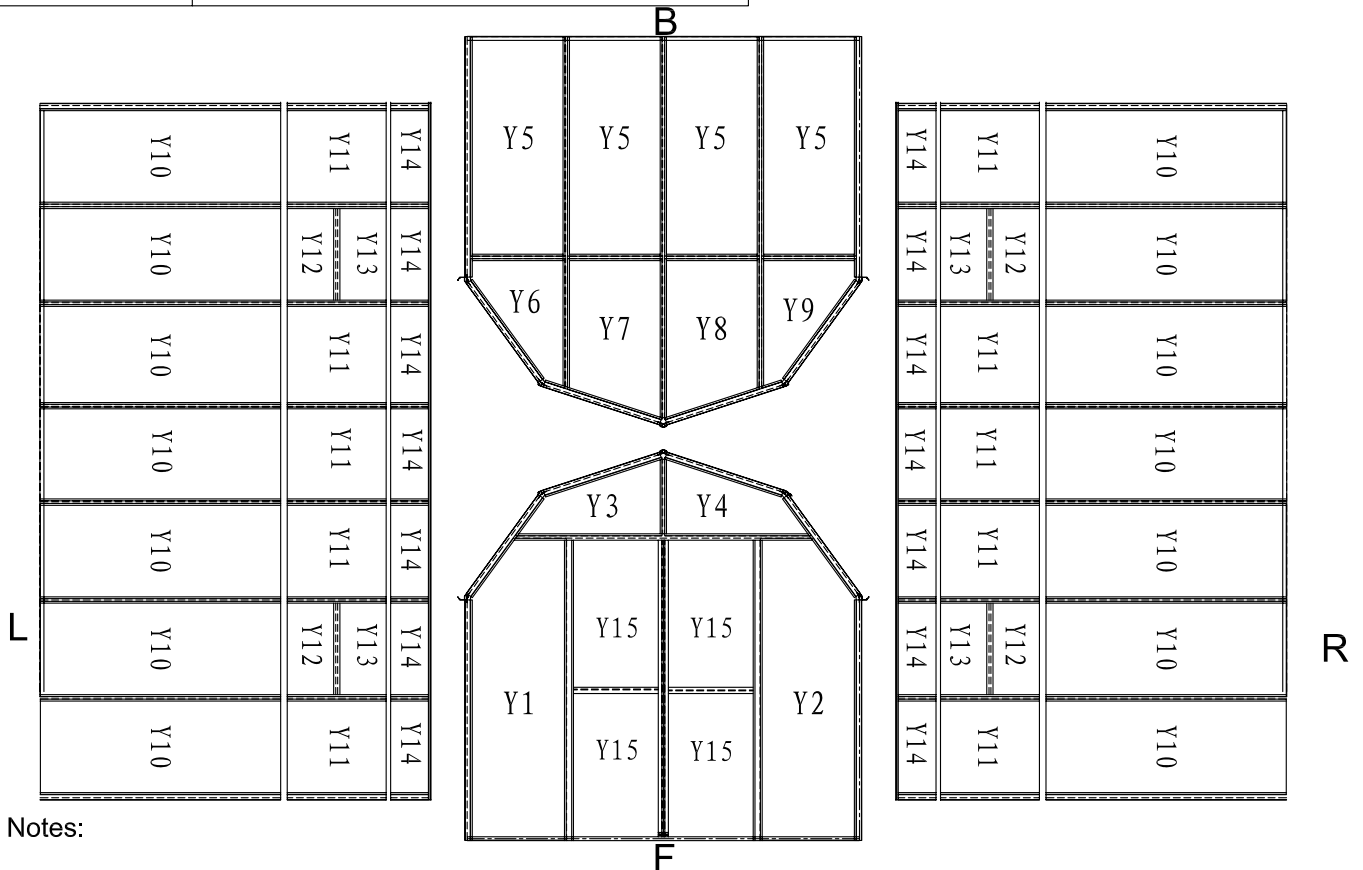

Notes:

1. Remove approximately 2 inches of film from all sheet edges before installing. Remove all film immediately after the construction is completed.
2. The UV-protected side of the sheet is covered with transparent film and must face towards the sun.

## BOLT INSTALLATION

- Please insert bolt into the groove firstly, and then turn the bolt clockwise until the bolt can't be turned any more.
- After finish turning the bolt, please move the bolt by hand and have the bolt thread nip the edge of the groove, so the bolt won't slide down.
- At last, install the bolt nut after connecting the parts that need to be connect.

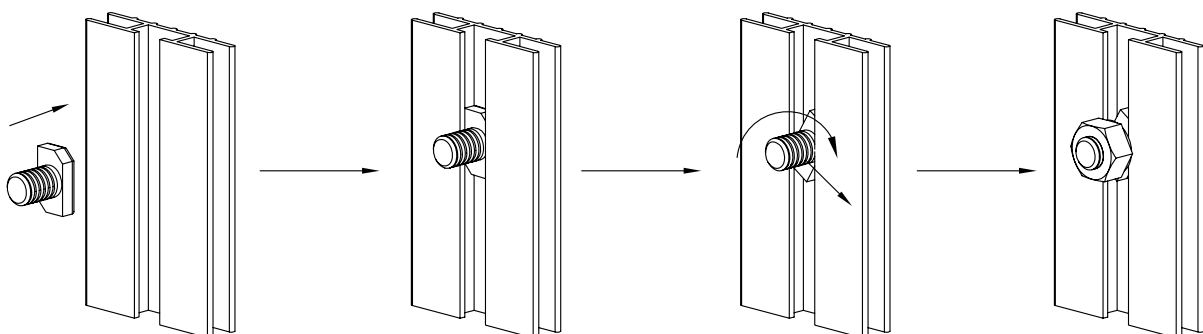



1

# FRONT FRAME ASSEMBLY

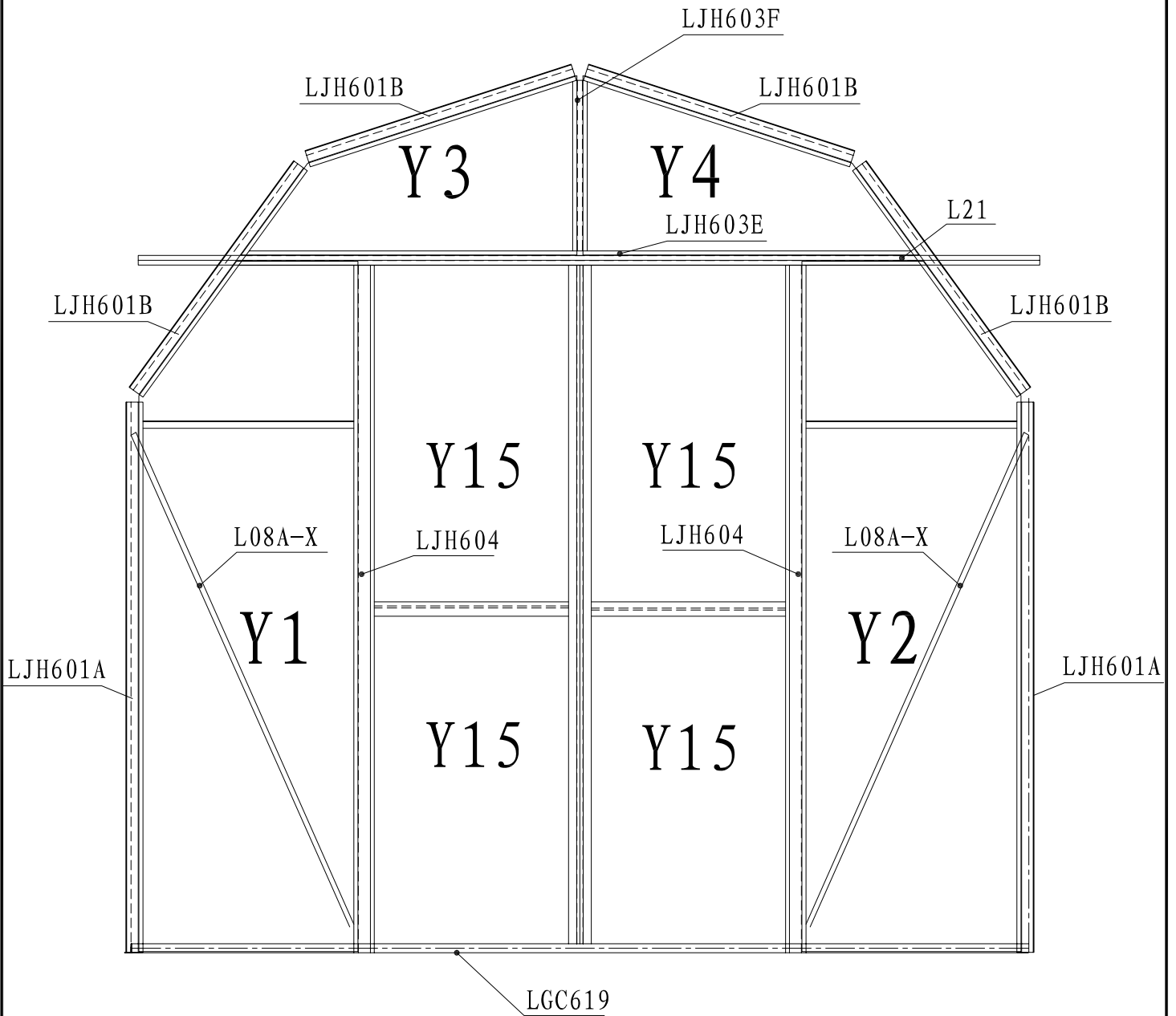

This picture shows the front aluminium frame assembly.

2 Please note the direction of LJH601A, LJH604 and LGC619. Install JJH606A on the pc board, then insert the PC board along the arrow.

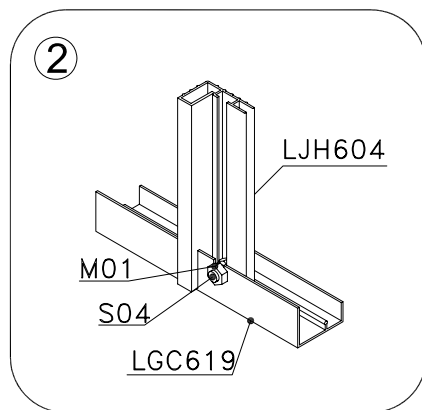
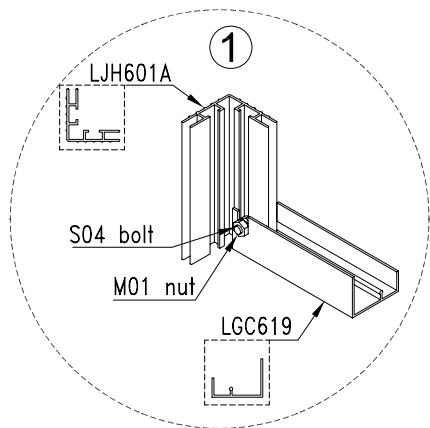
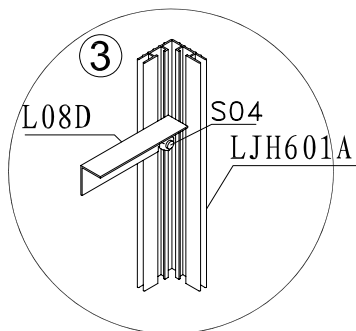
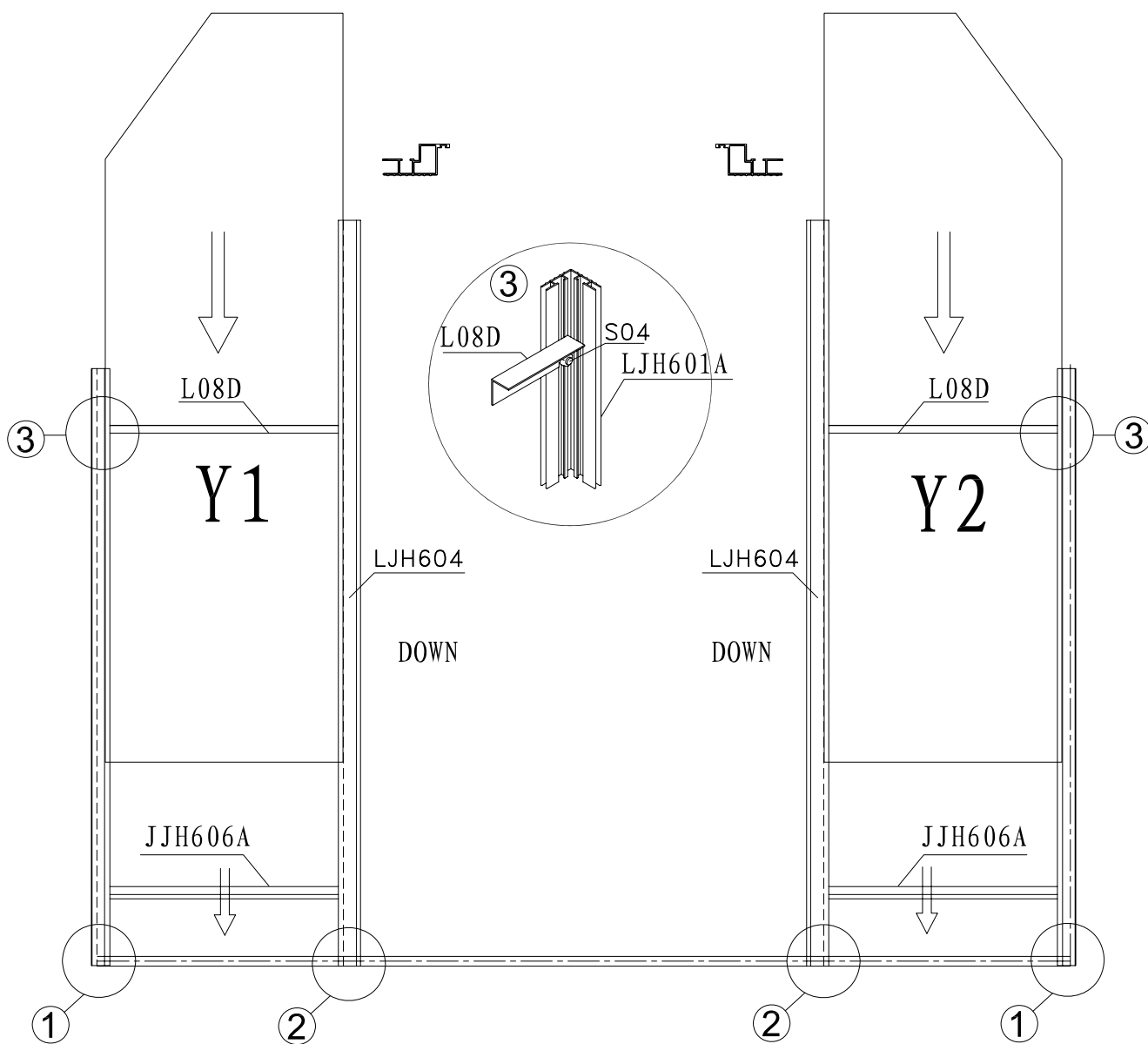

3

Very important:

When installing WG01 & WG02, please use LGC607 localizer & LGC609 localizer to locate WG01 & WG02 into right position, and then take out LGC607 localizer & LGC609 localizer for later use. (Localizer is a special tool)

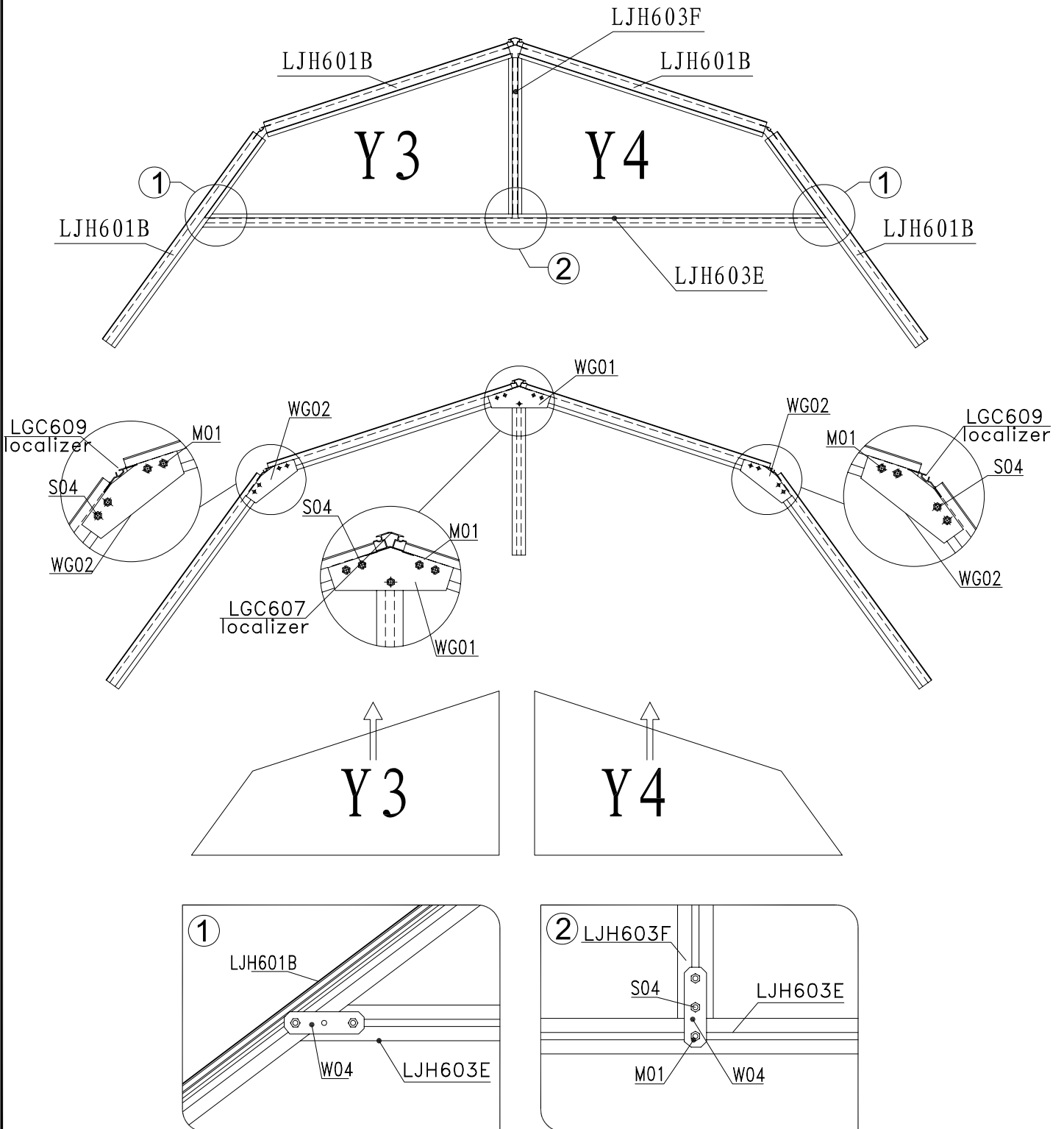

4

Very important:  
When installing WG02, please use LGC609 localizer  
to locate WG02 into right position, and then take out  
LGC609 localizer.

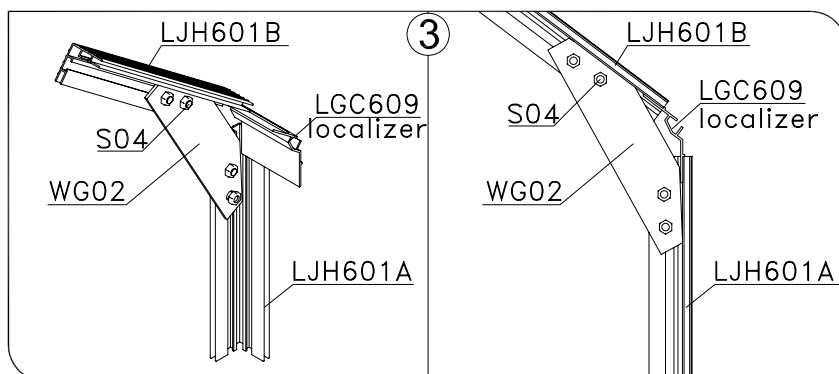
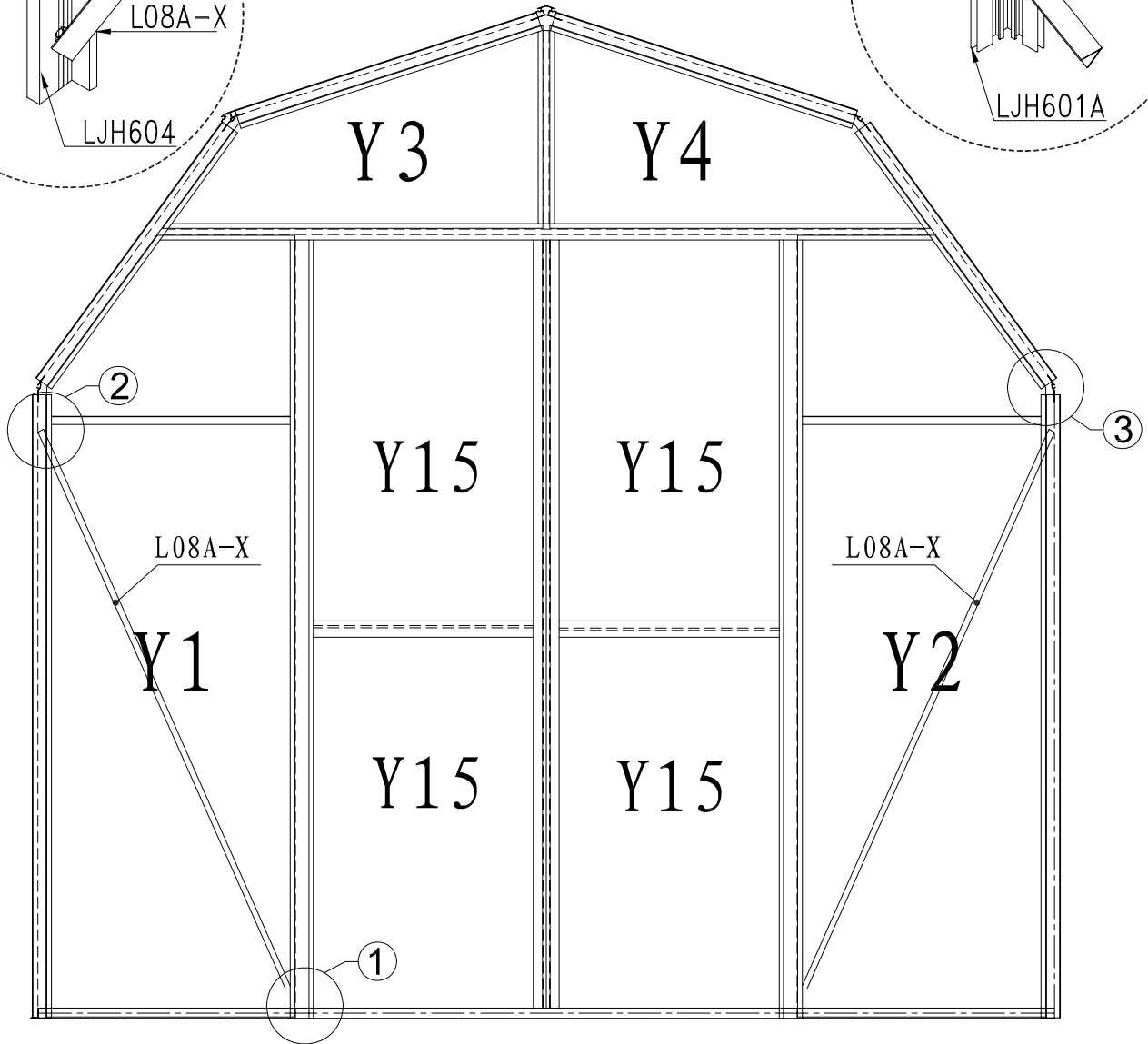
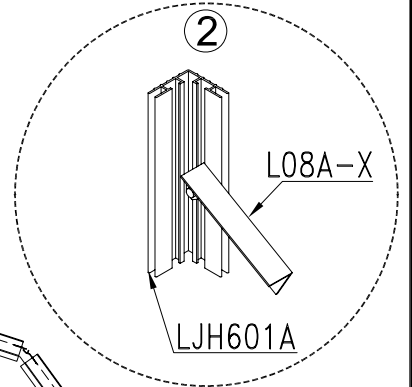
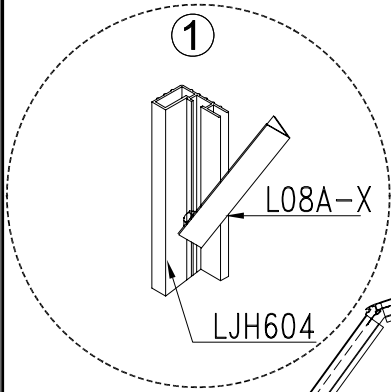

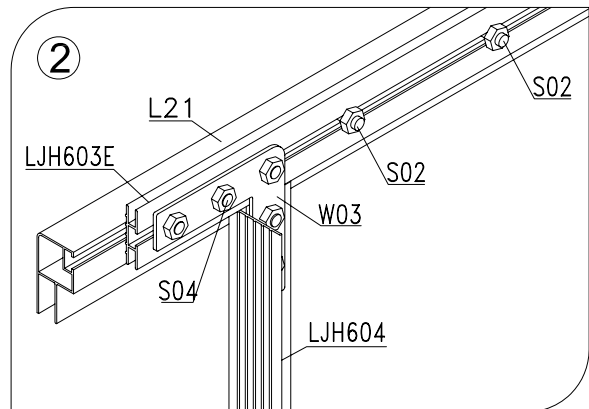
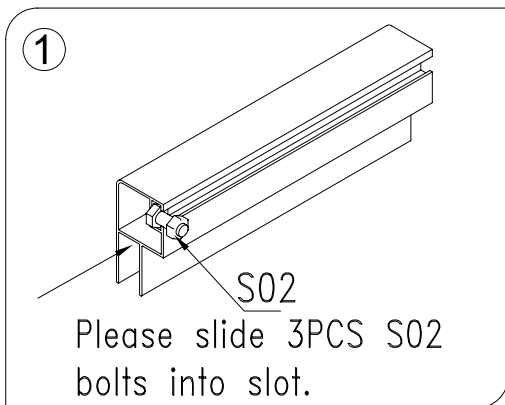
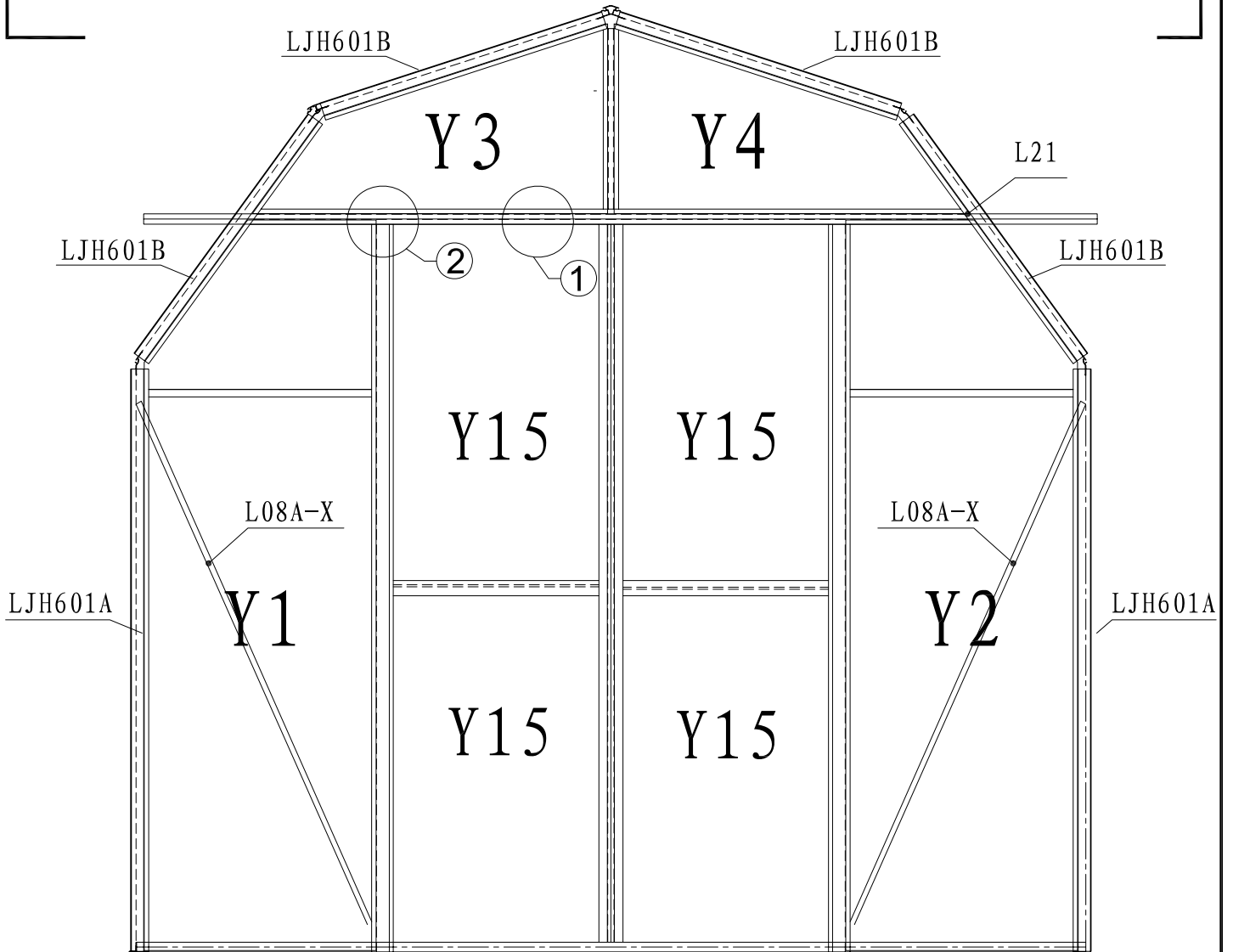

## BACK FRAME ASSEMBLY

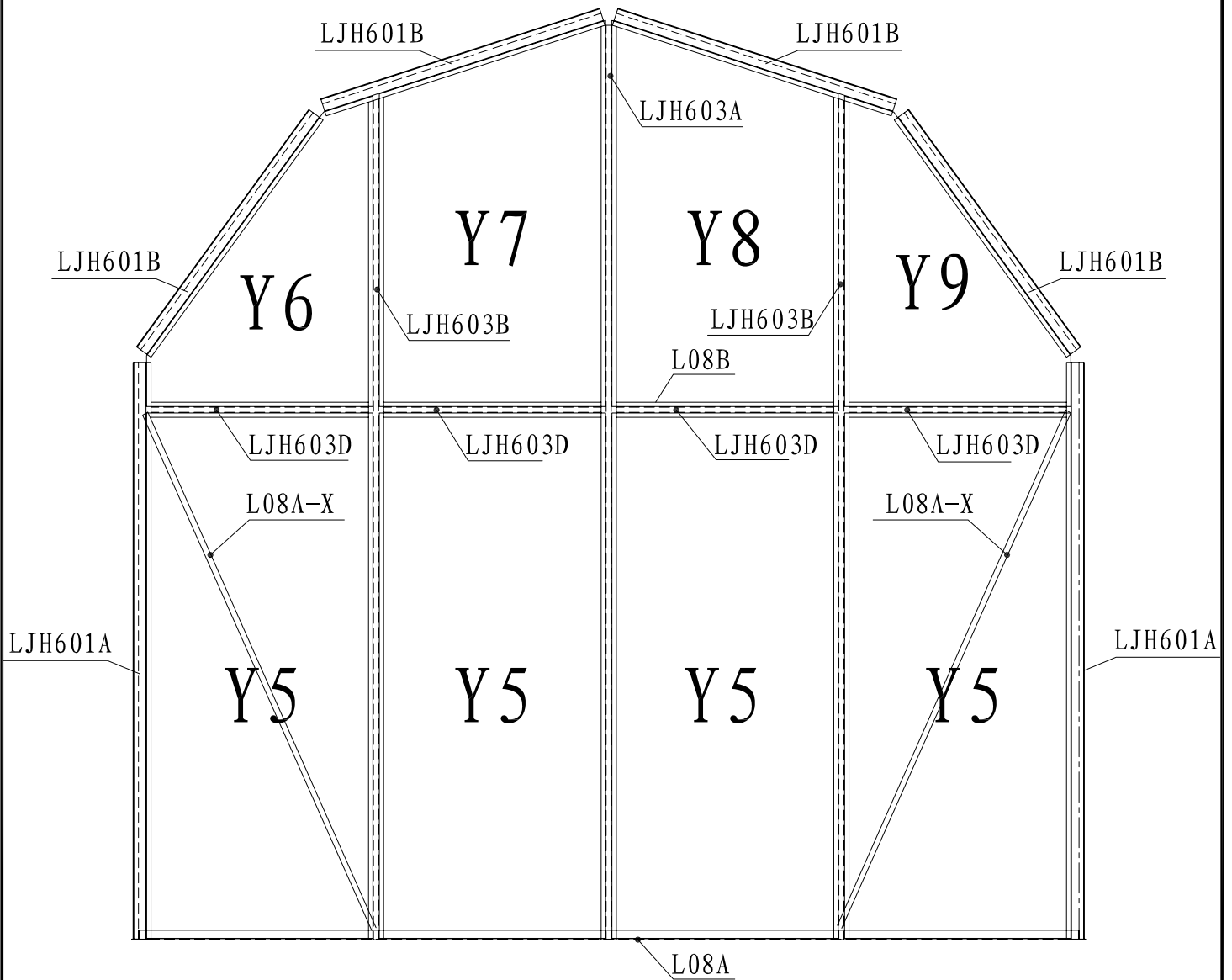

This picture shows the back aluminium frame assembly.

7

1. Install JJH606B on PC board(Y5) before inserting PC board into the frame.

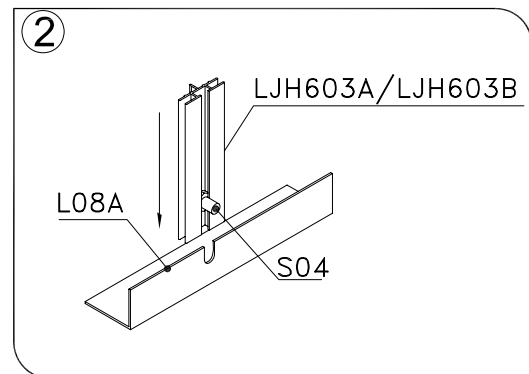
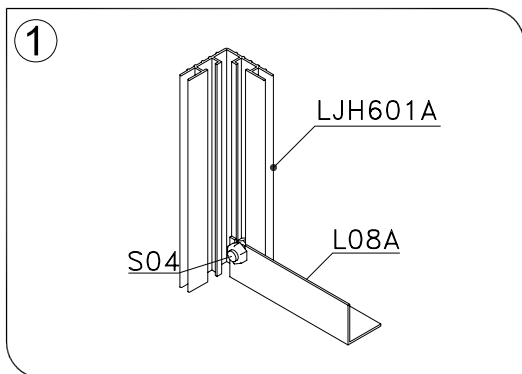
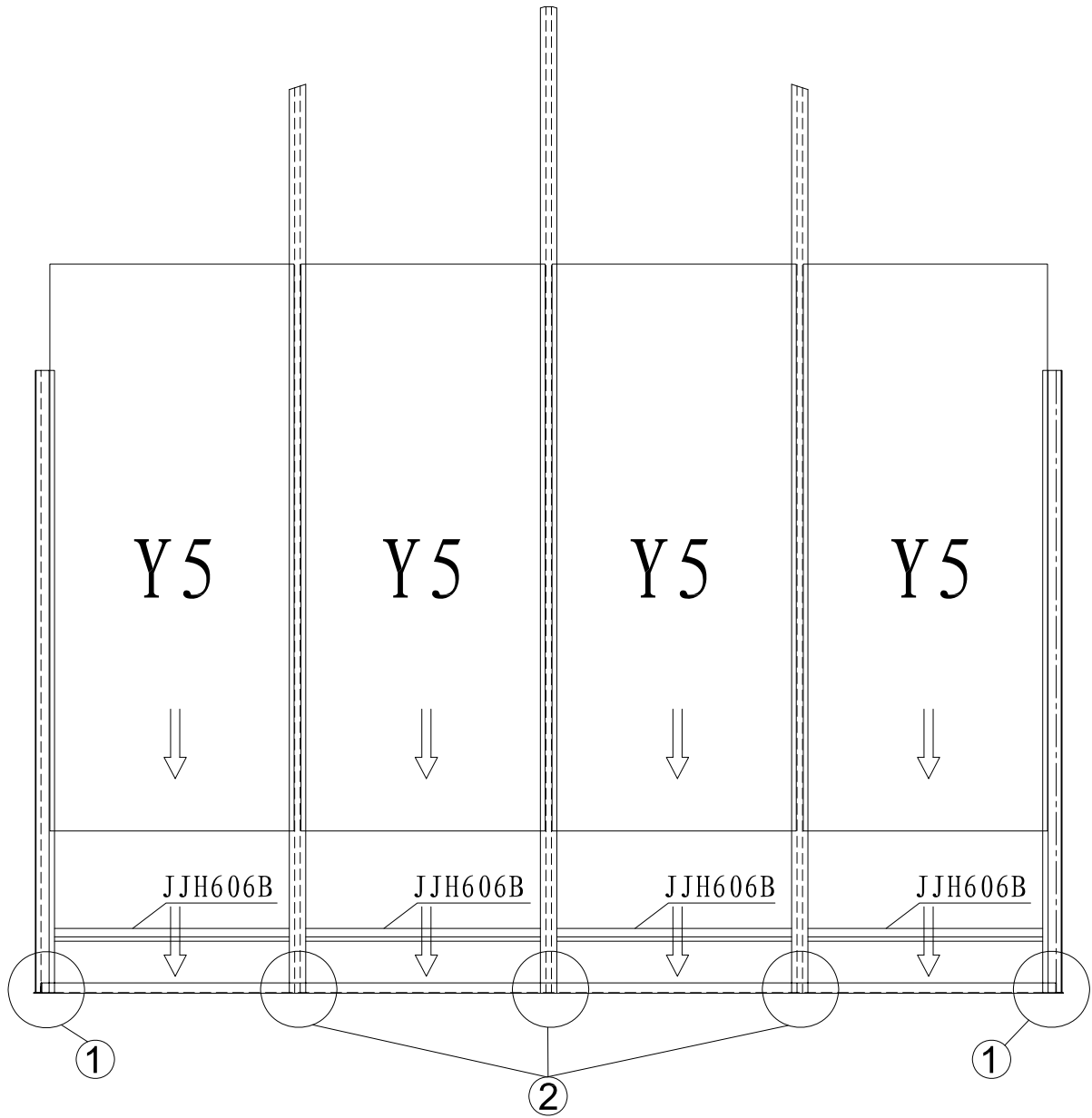

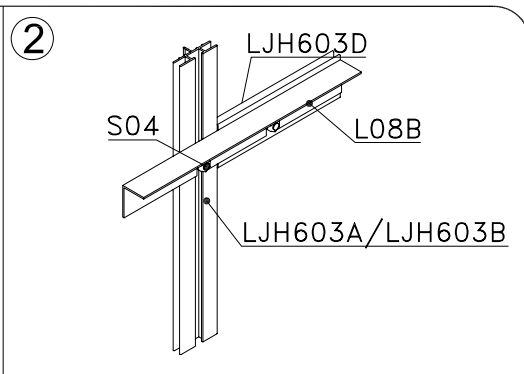
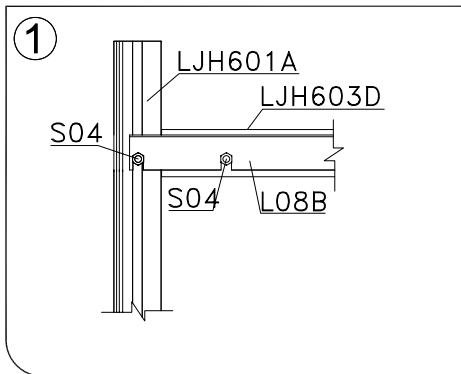
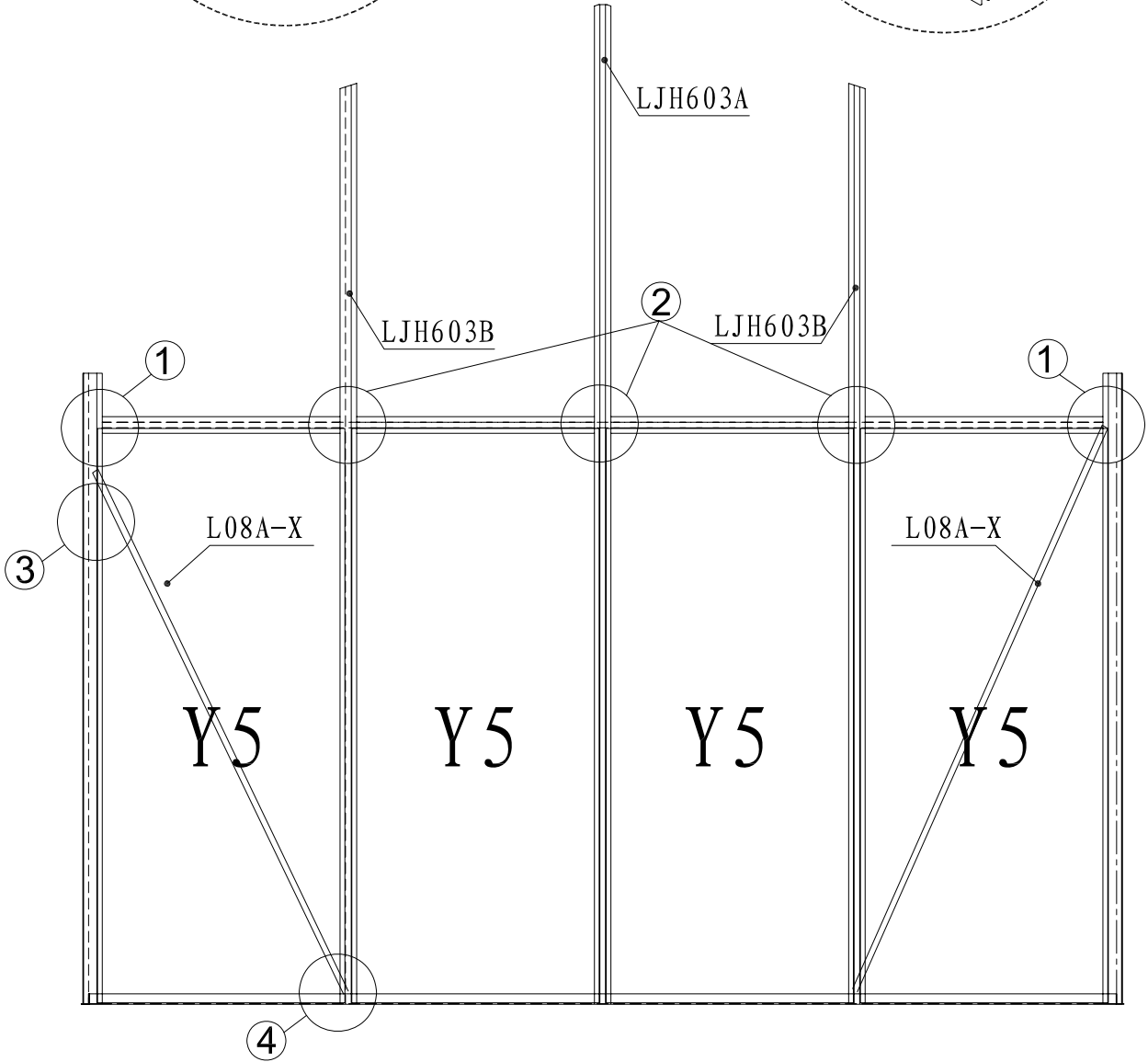
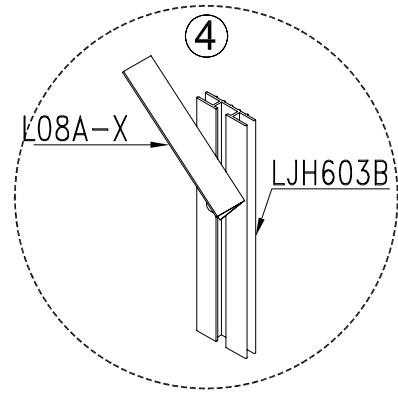
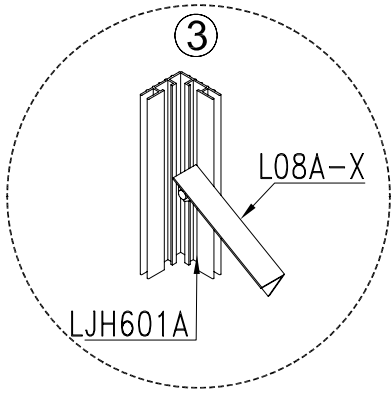

9

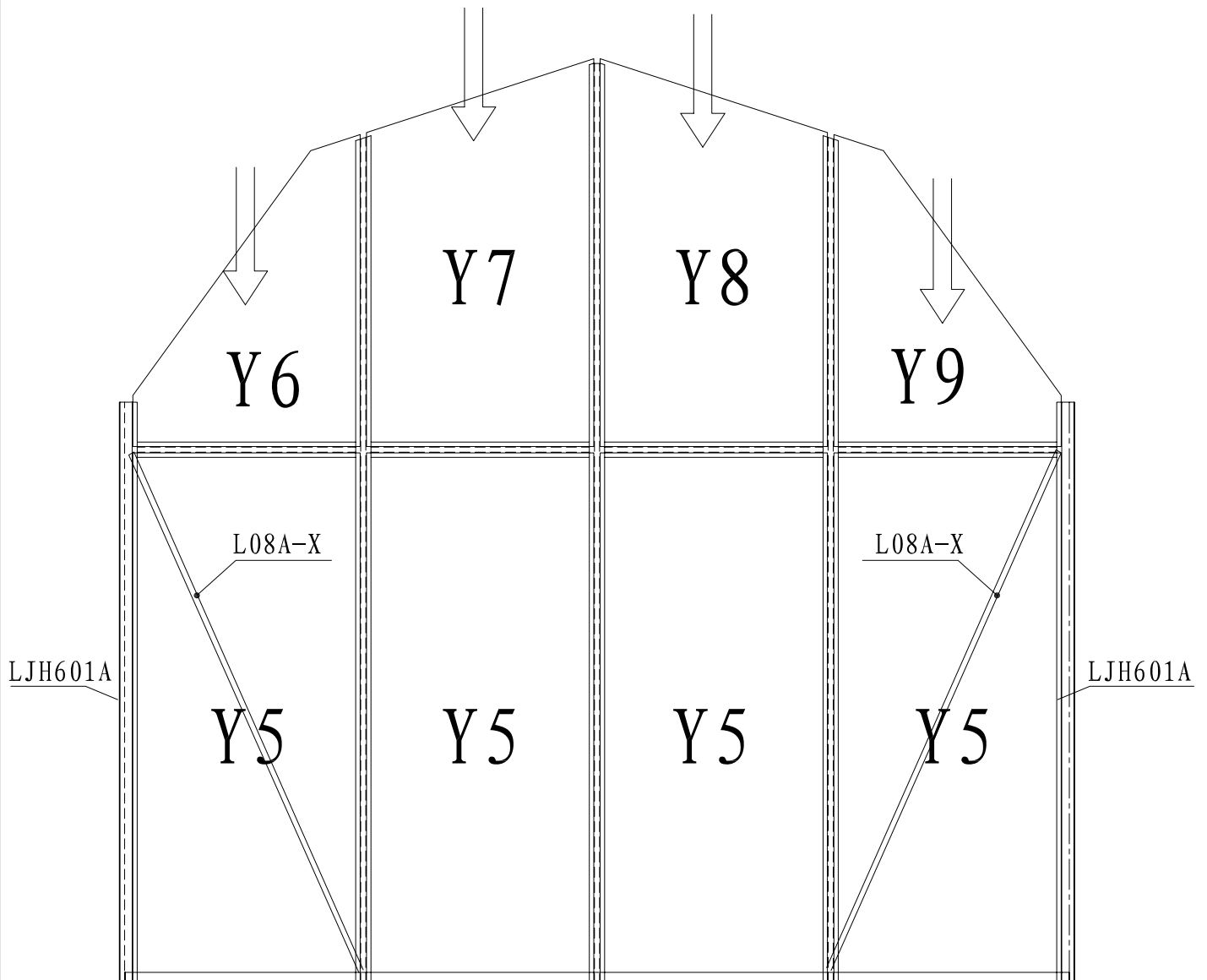

10

Very important:

When installing WG01 & WG02, please use LGC607 localizer & LGC609 localizer to locate WG01 & WG02 into right position, and then take out LGC607 localizer & LGC609 localizer. (Localizer is a special tool)

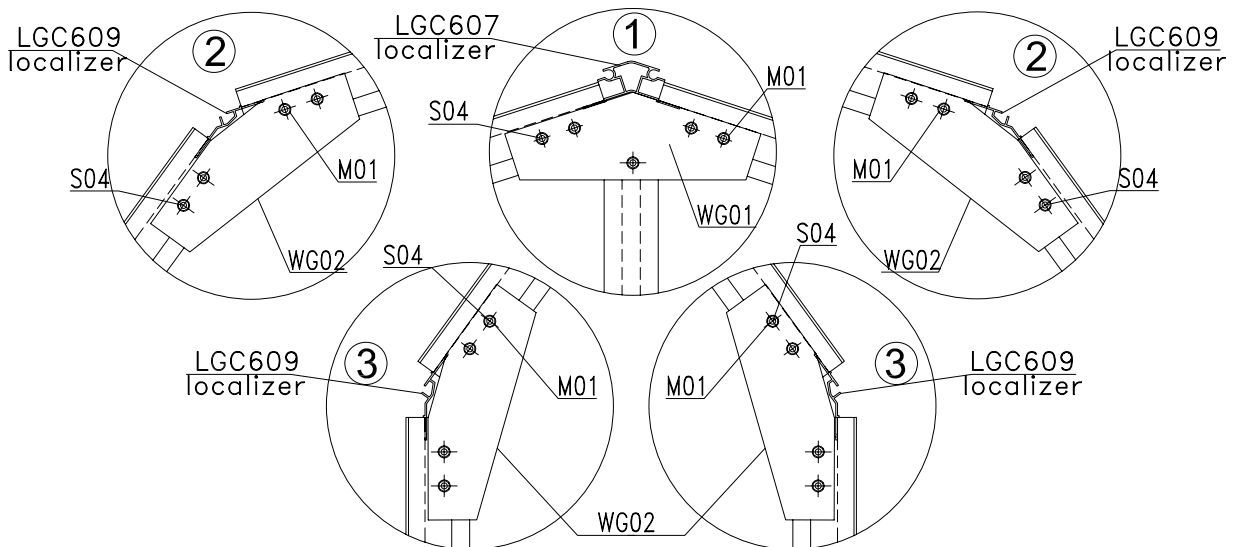
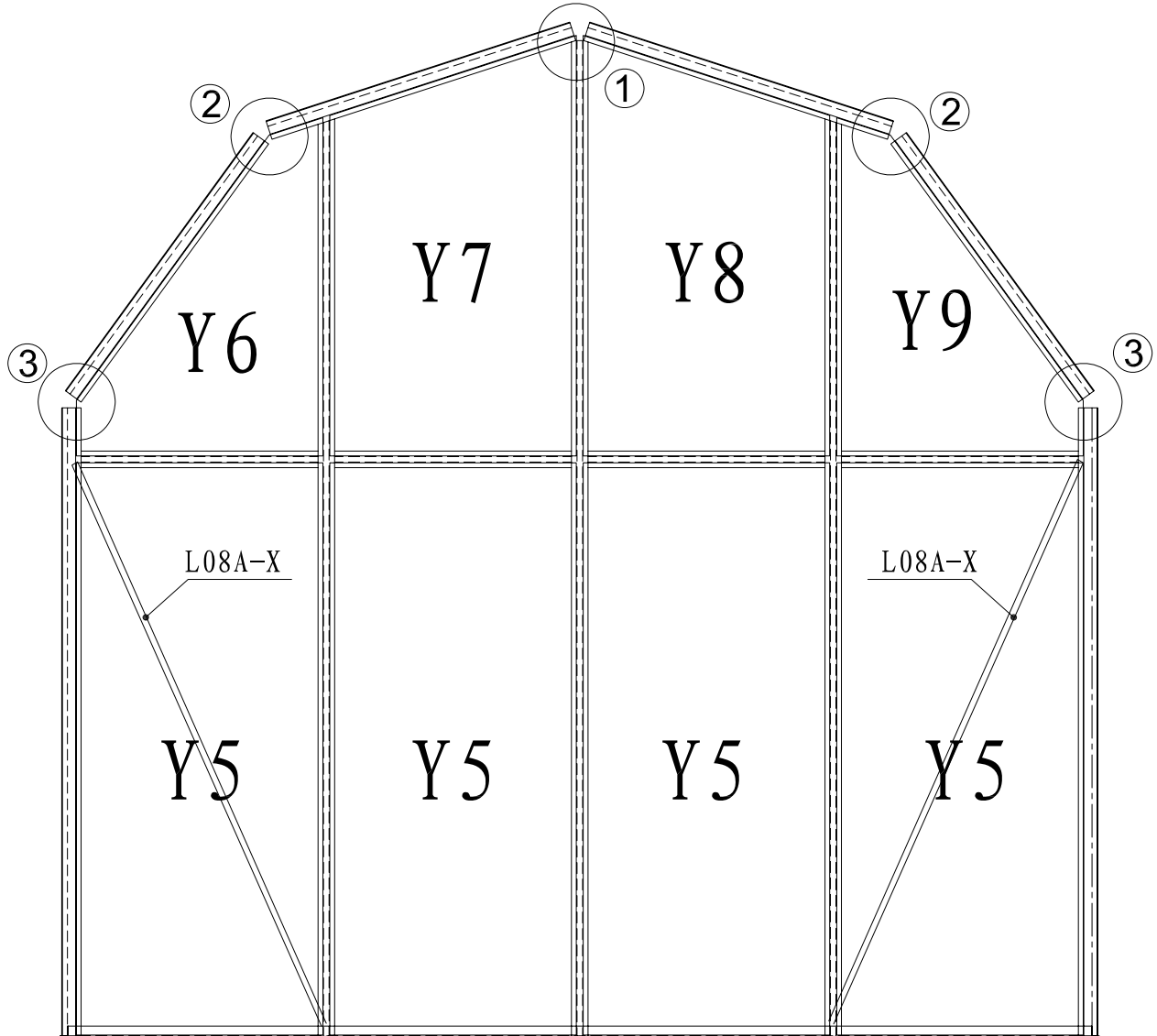

# WHOLE ASSEMBLY

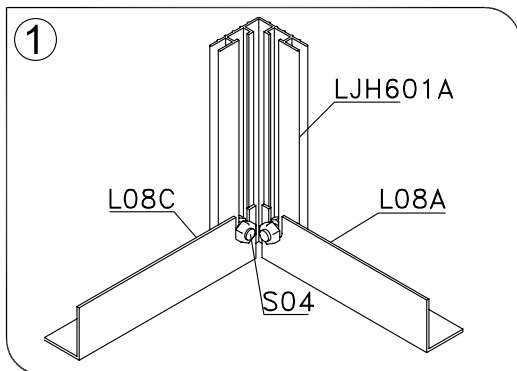
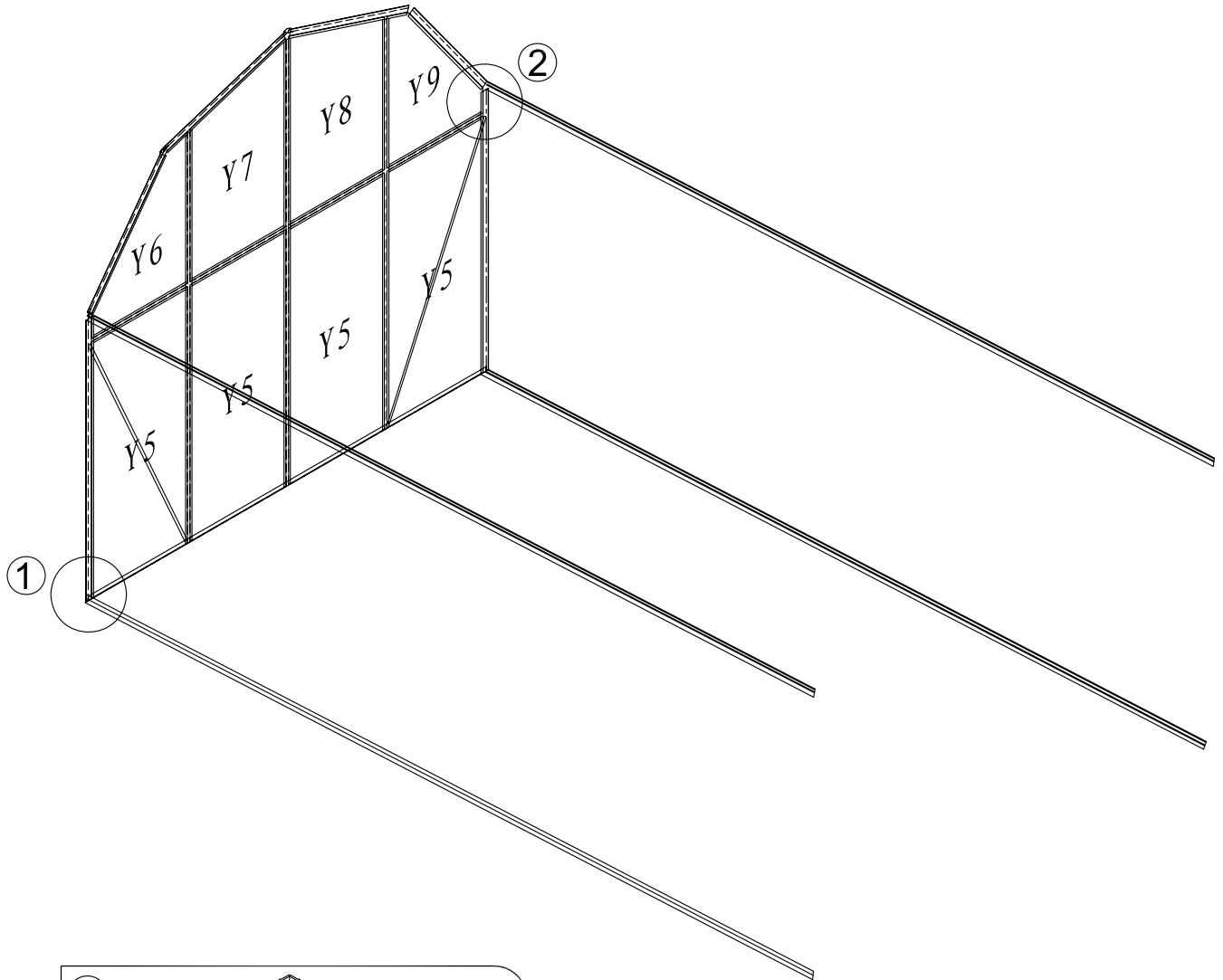

Adjust the position of S04 bolt to prevent scratching between other pieces.

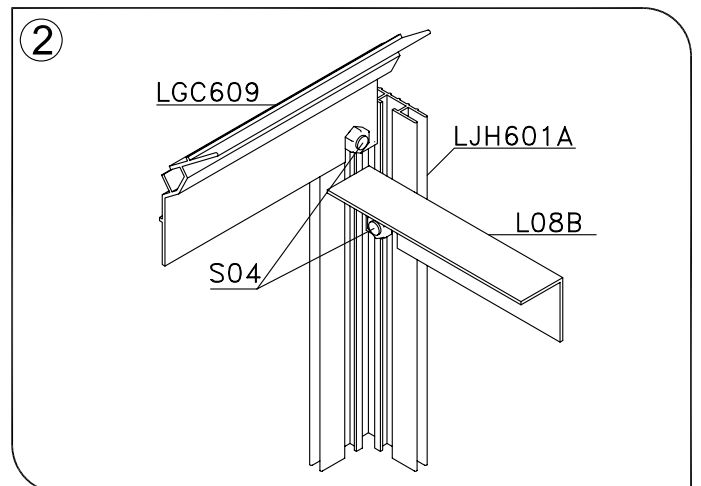

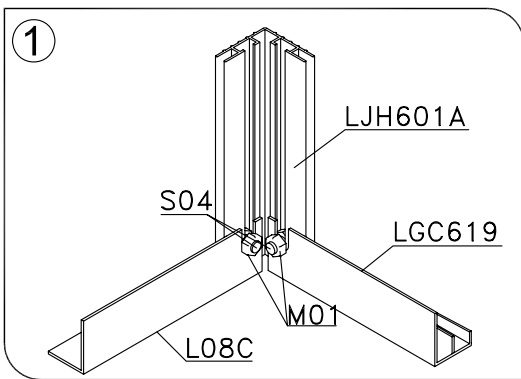
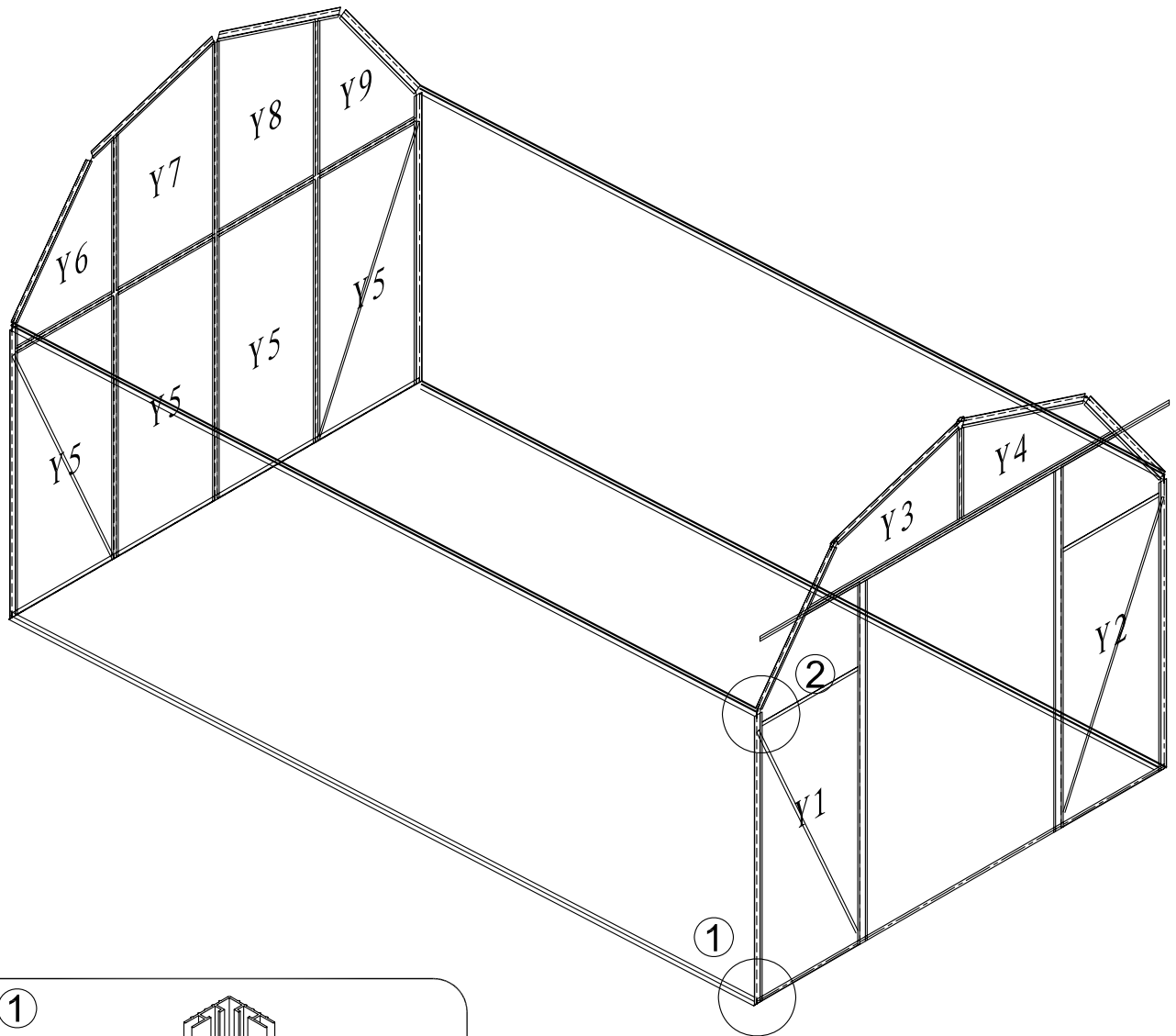

Adjust the position of S04 bolt to prevent scratching between other pieces.

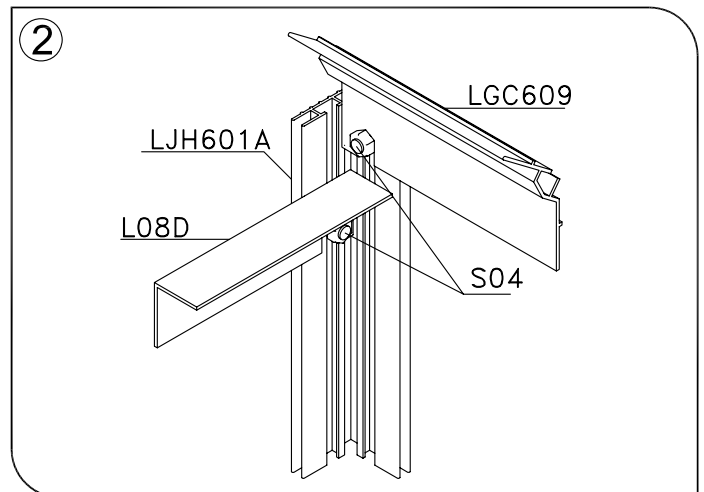

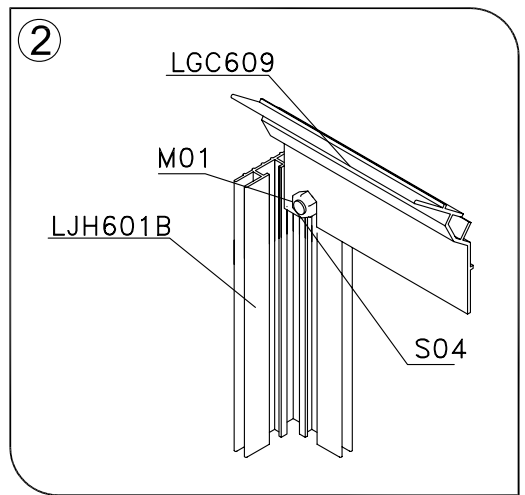
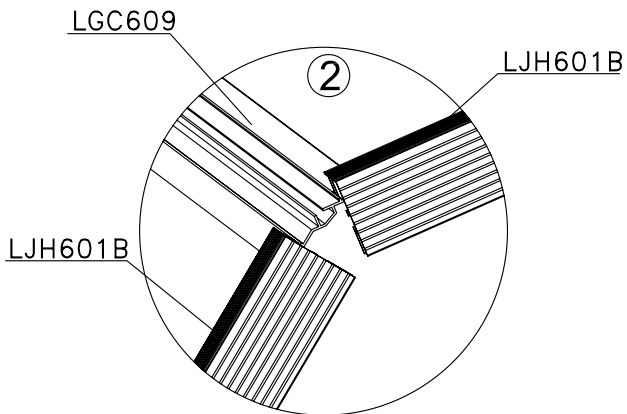
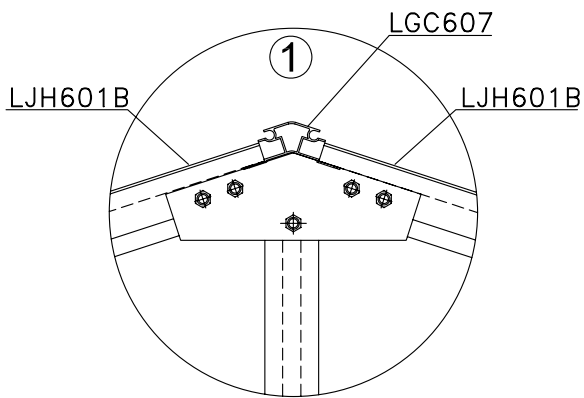
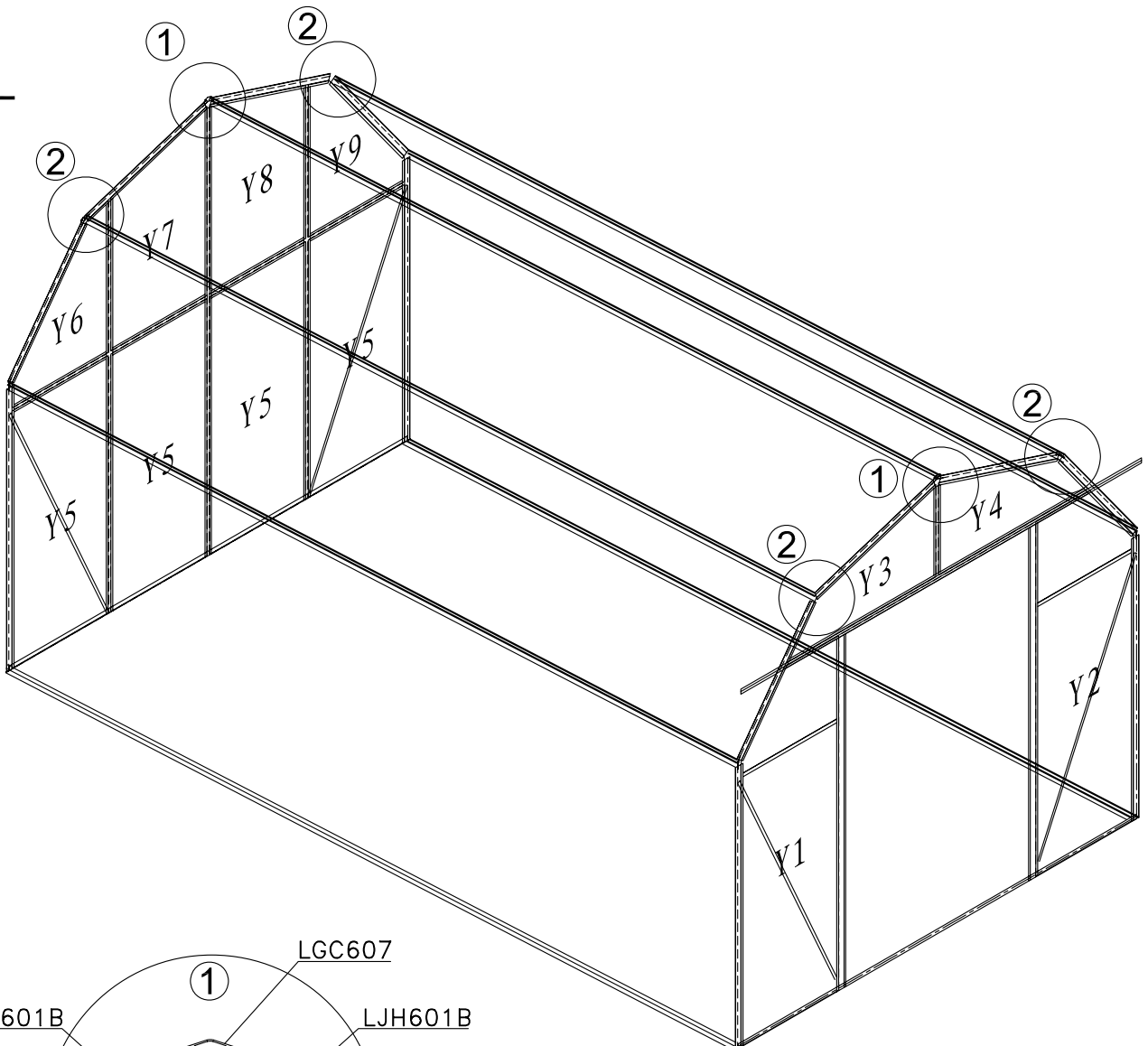

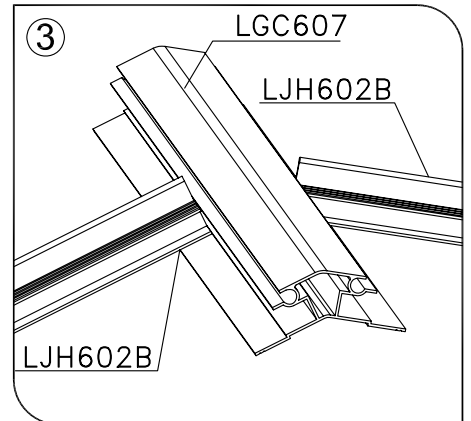
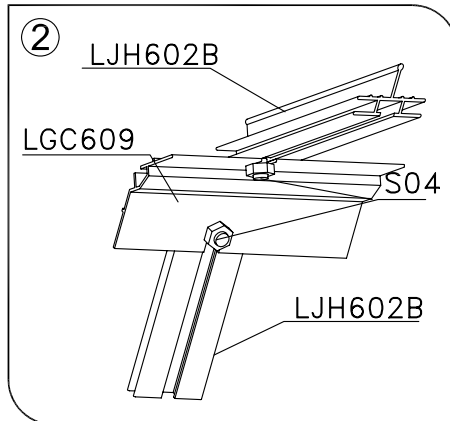
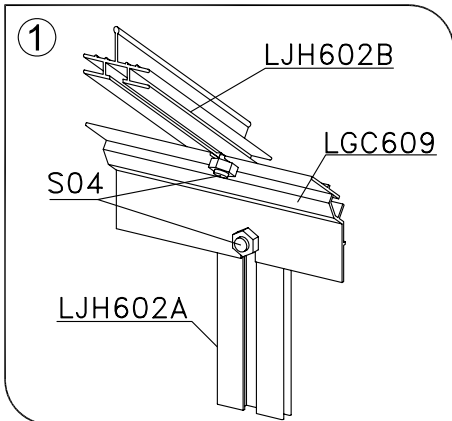
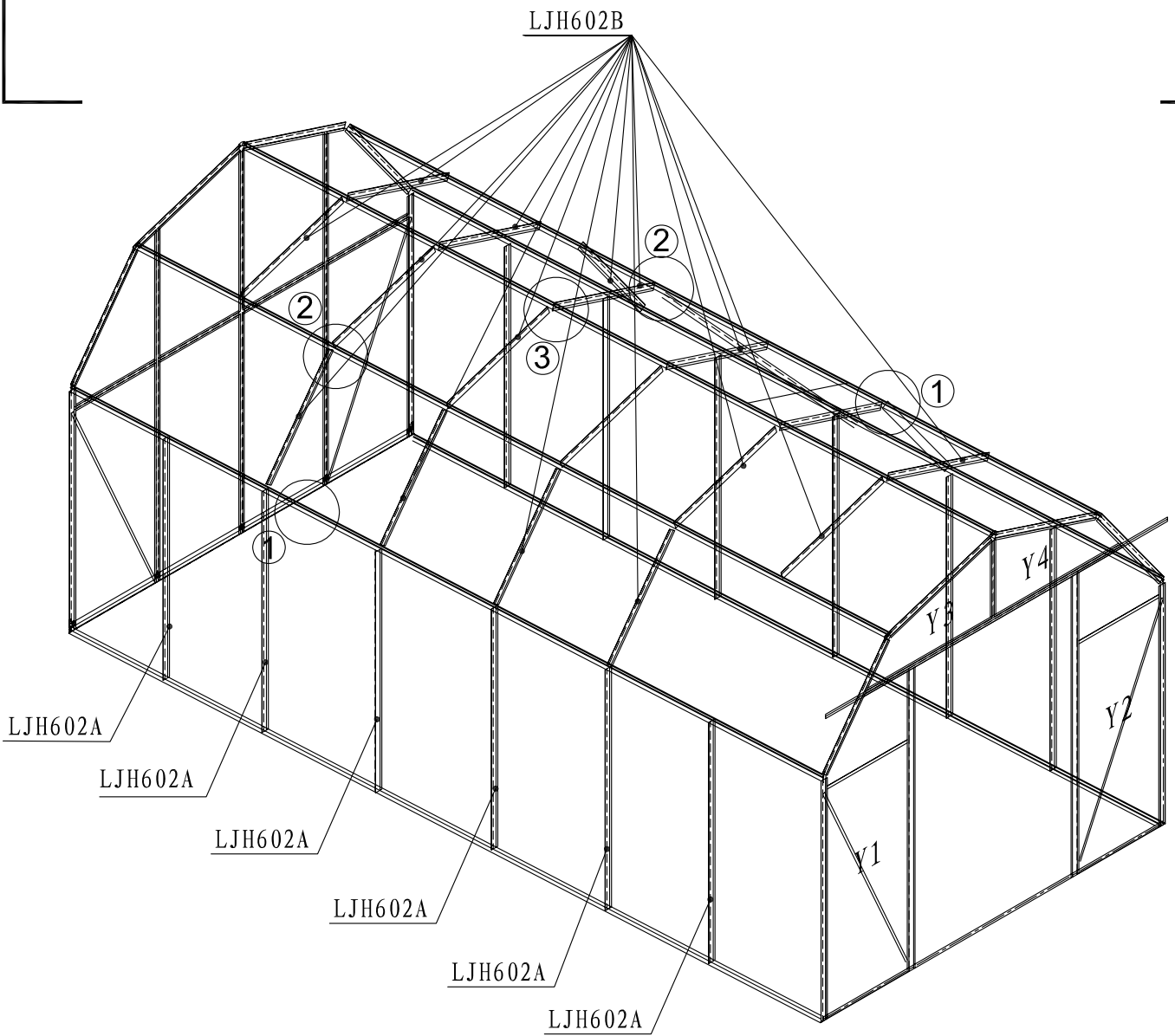



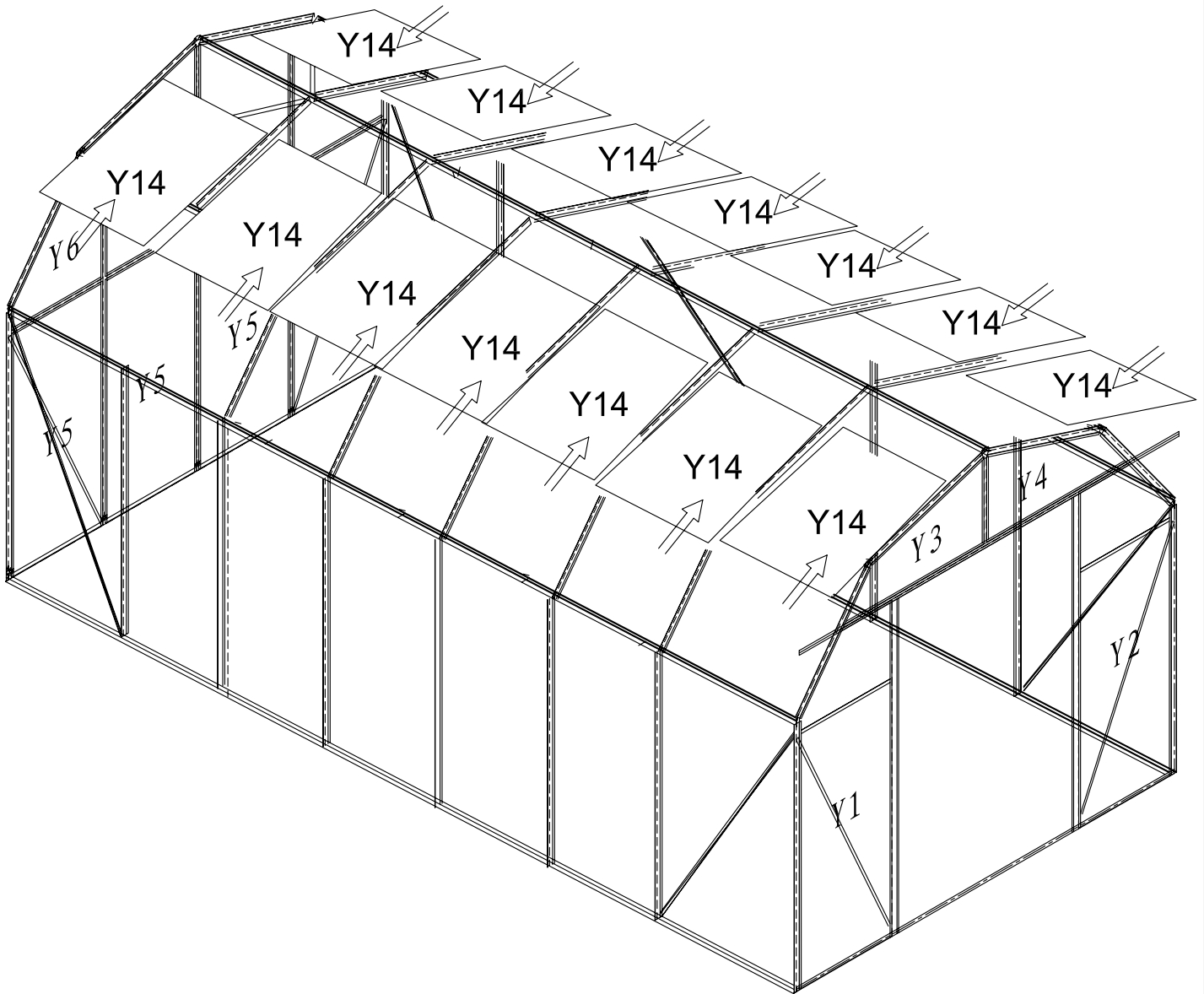

17

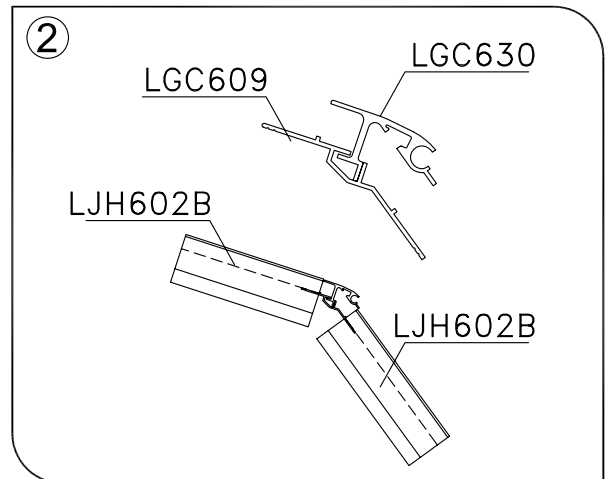
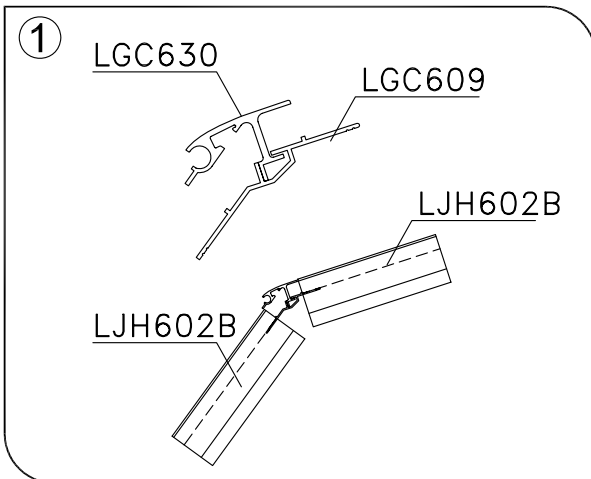
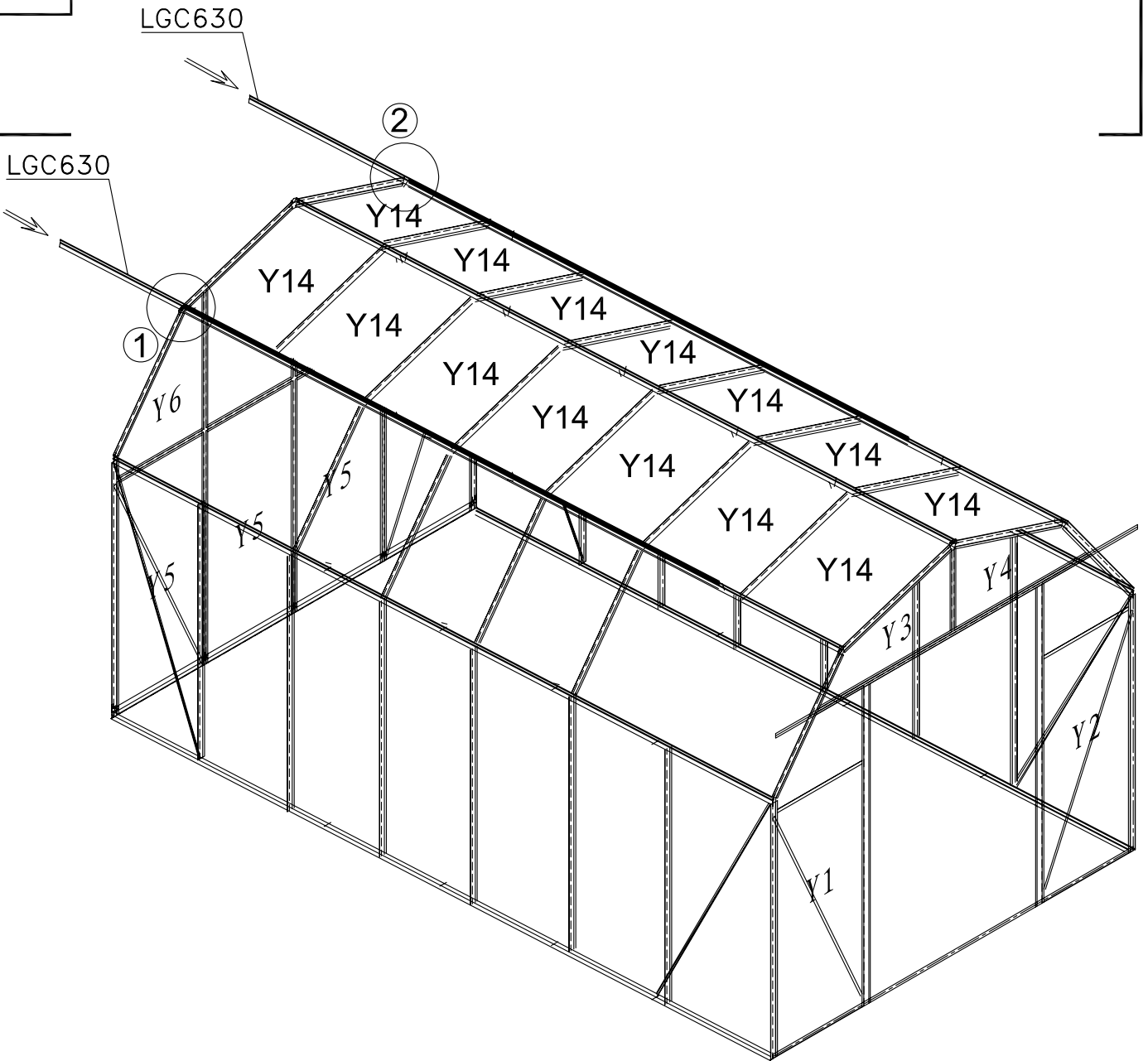

18

# Window assembly

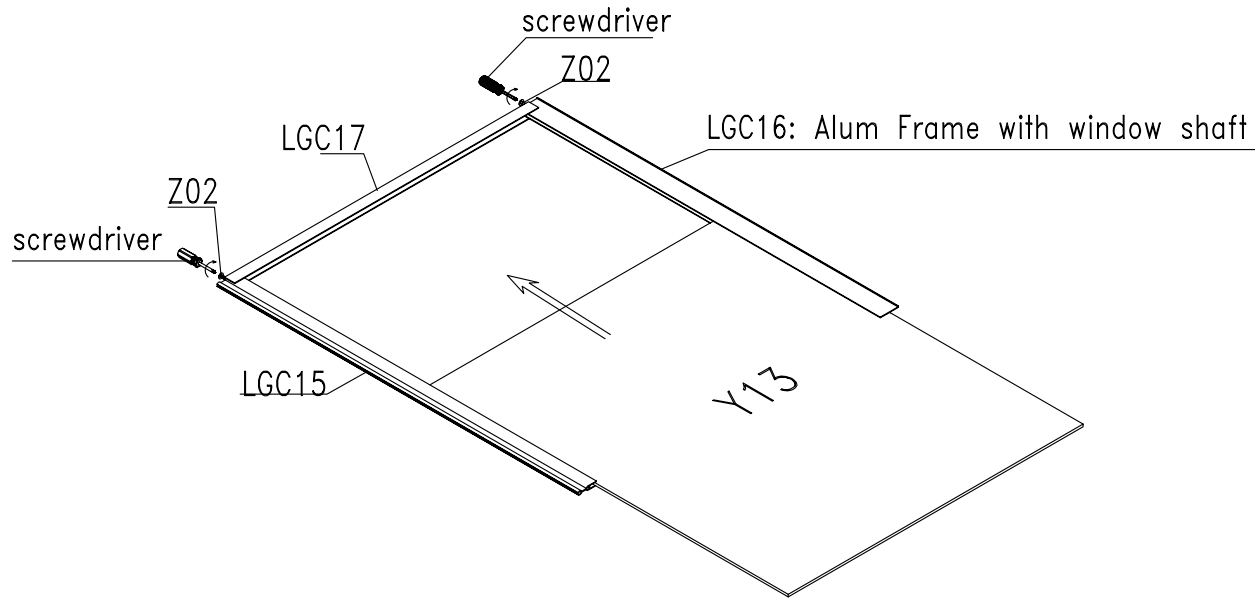

19

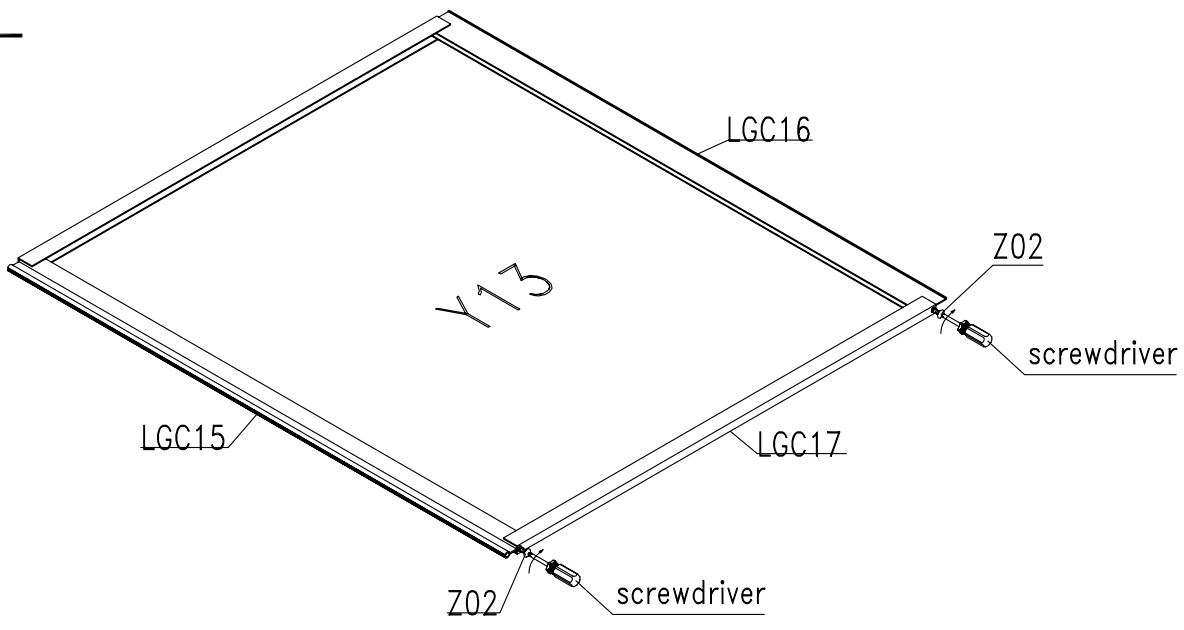

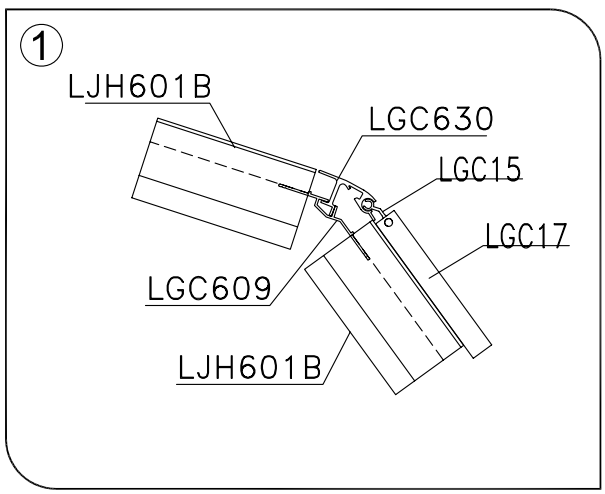
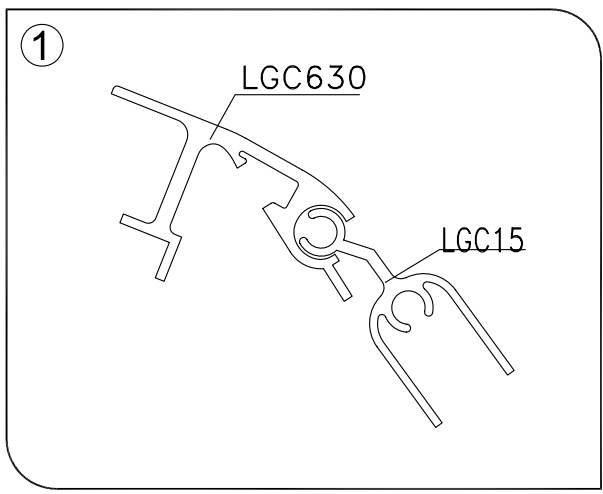
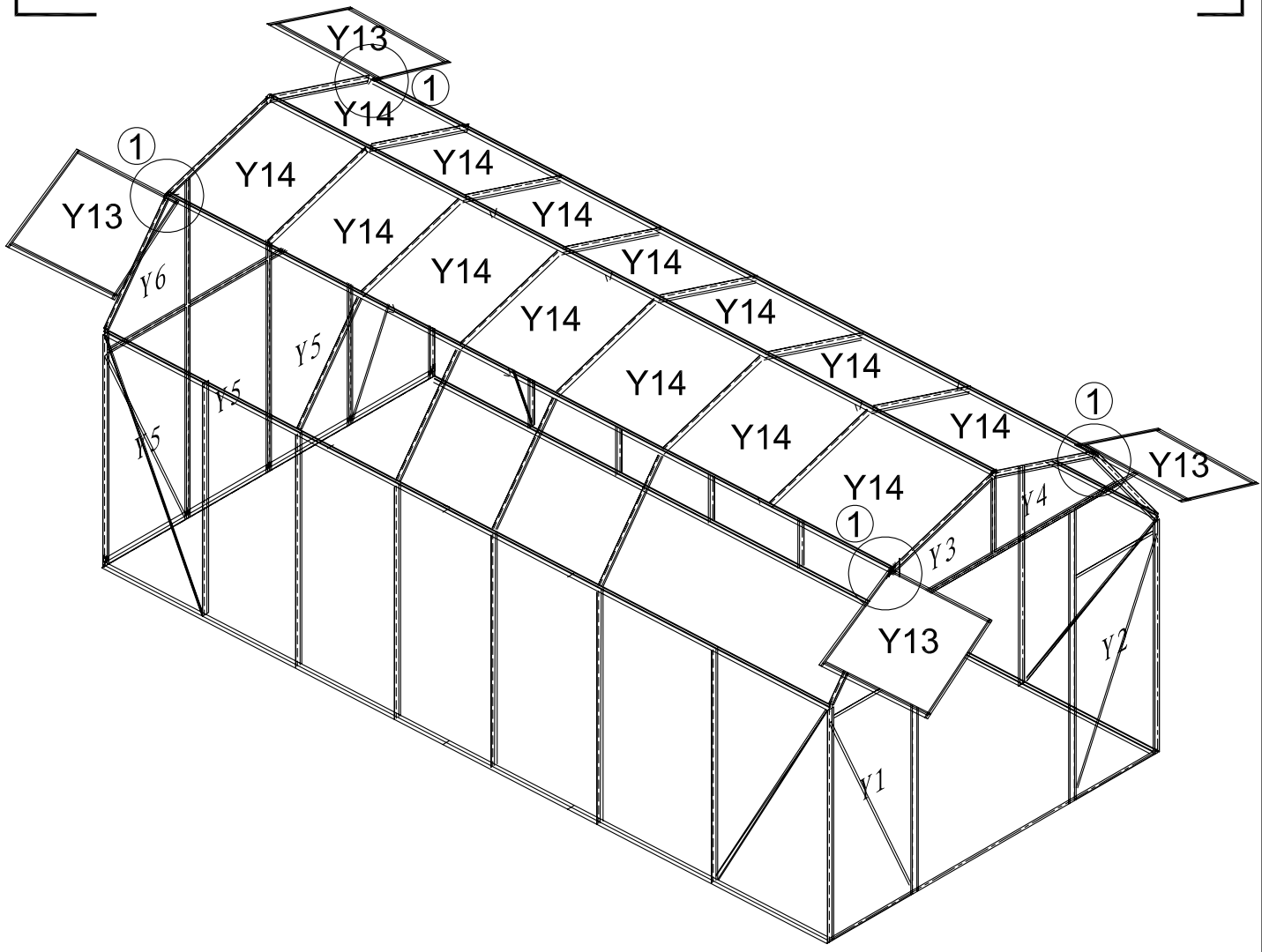

L08B-X

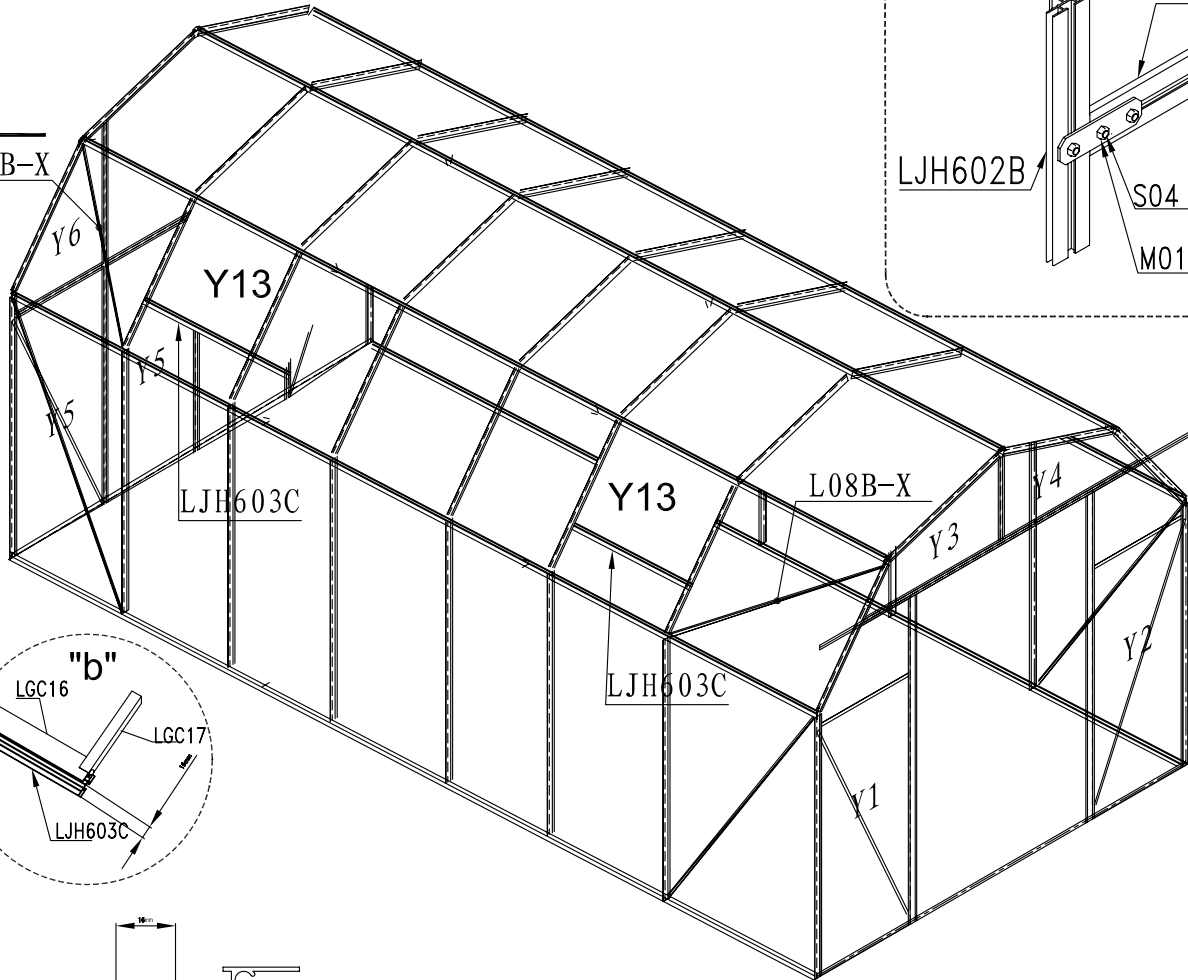
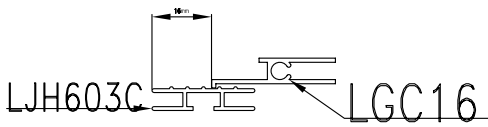
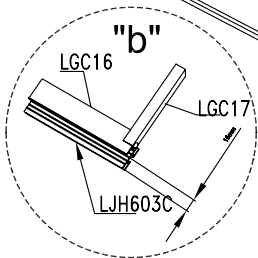
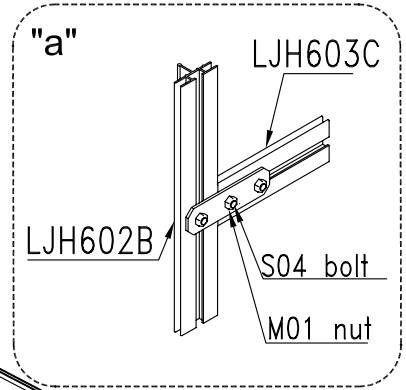

Window support assembly instruction

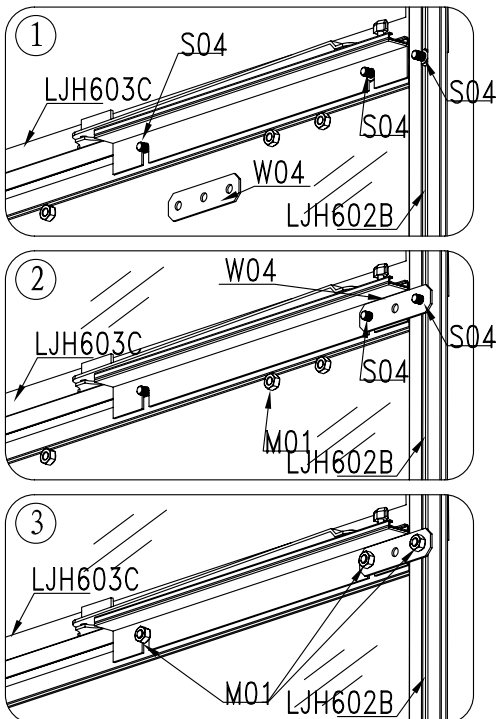

1. After installing 2pcs S04 bolt into LJV603C in advance, aim the opening of angle aluminium that is connected with window support at the S04 that already been installed in advance.

2. Aim the right hole of W04 at S04 that have been installed into LJV602B in advance, and aim the left hole of W04 at S04 that have been installed on the LJV603C in advance (When installing W04, Angle aluminium and S04 that been installed in advance need to be adjusted a little for installing W04).

3. Connect M01 to S04 and then tighten, so the window support can work well.

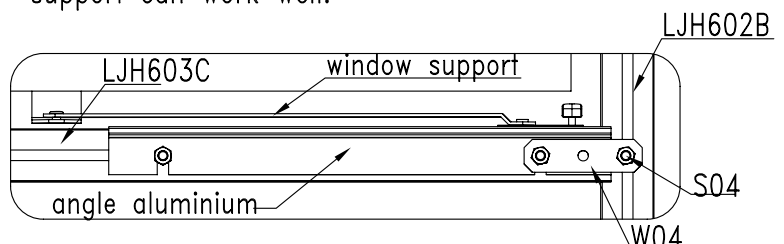

22

First install JJH606C on PC board Y10, and then insert Y10 along the arrow.

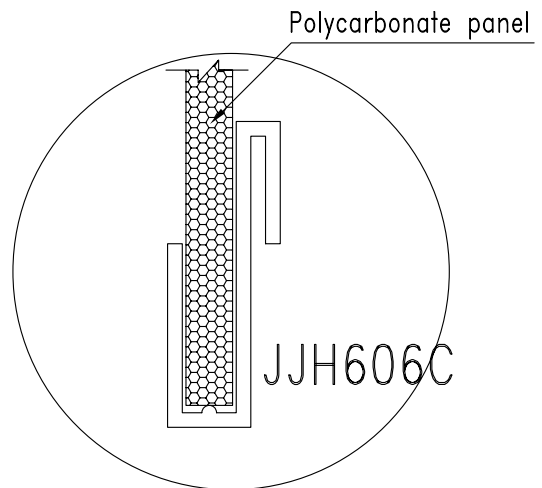
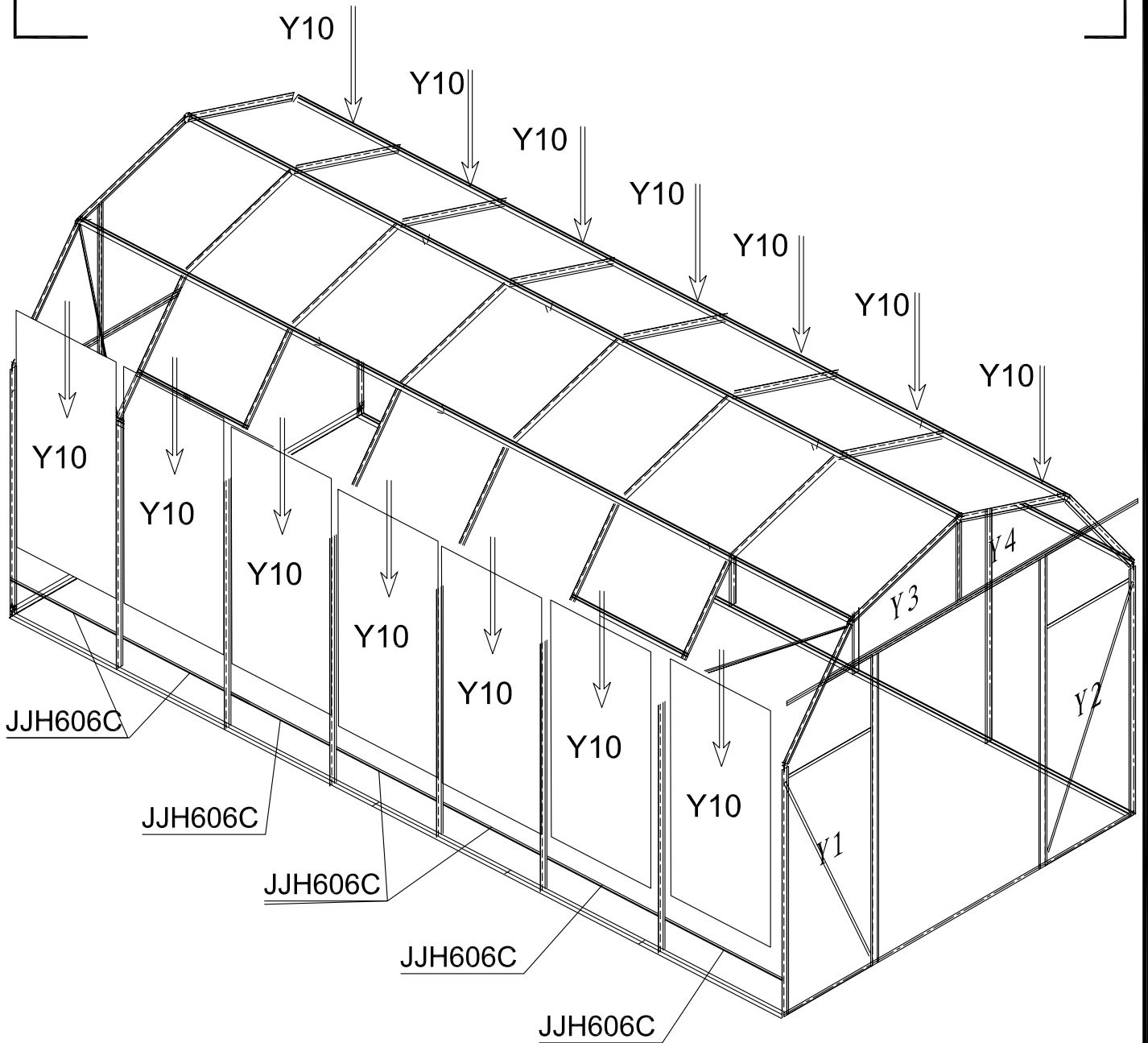

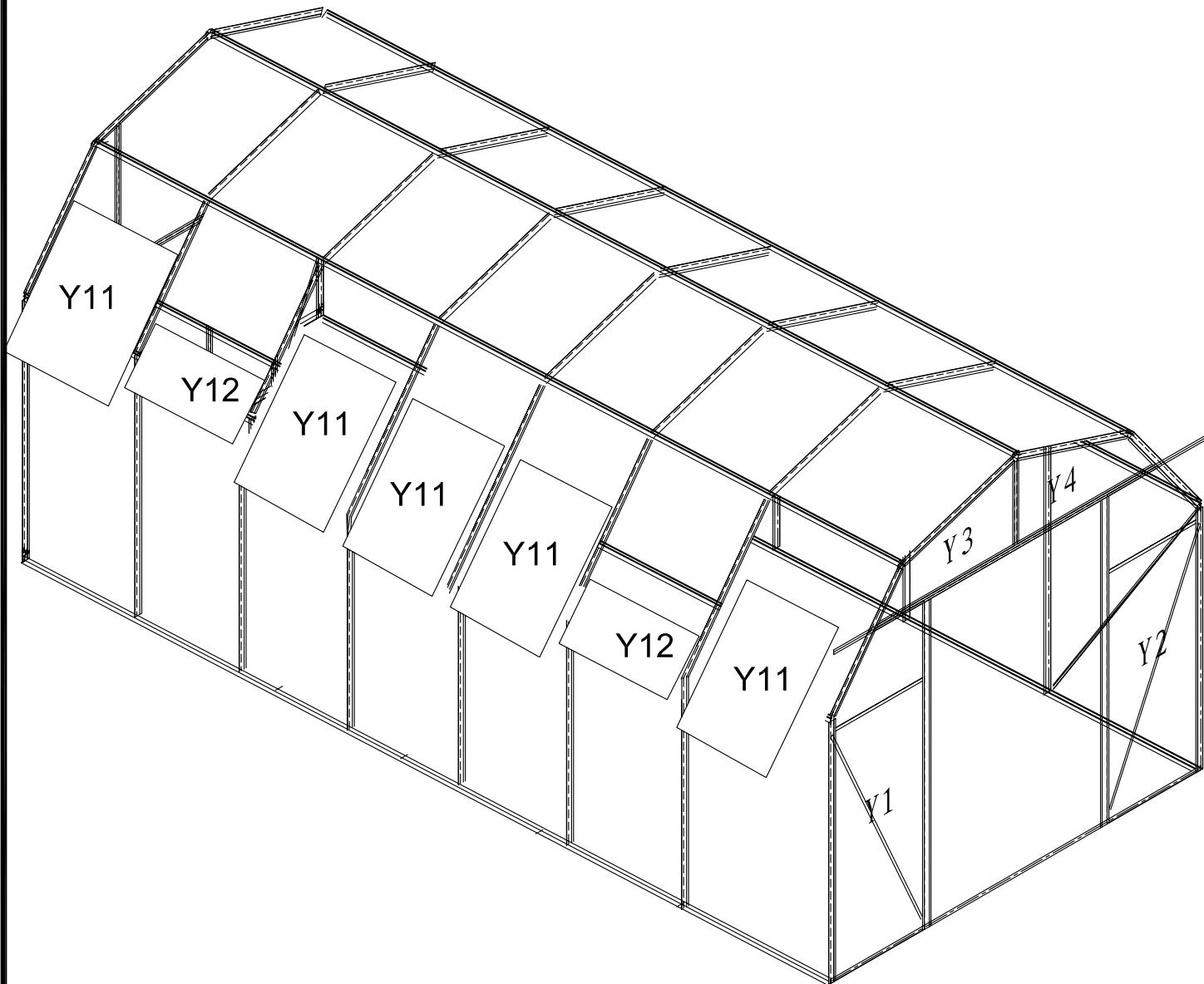

24

If you encounter resistance when installing LGC610, and you have no way to use hand to install LGC610 into the right location, please use the matching rubber hammer to hammer parts into the right location.

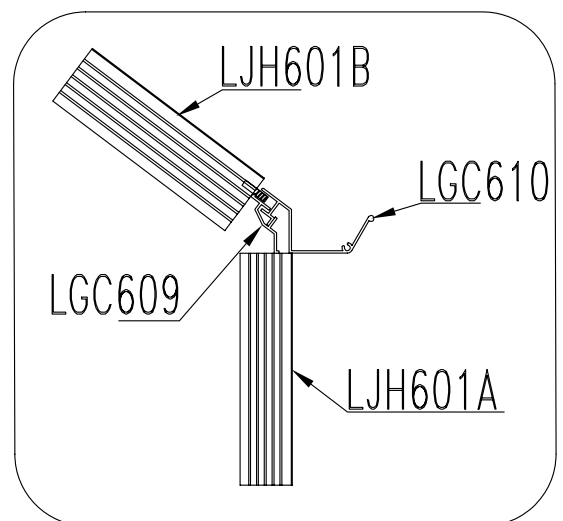
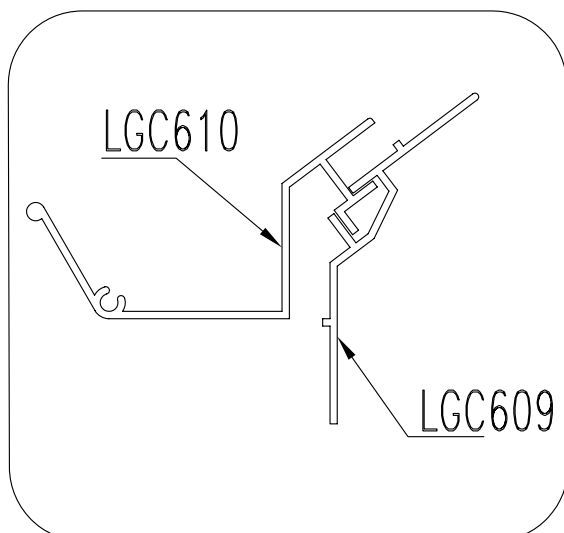
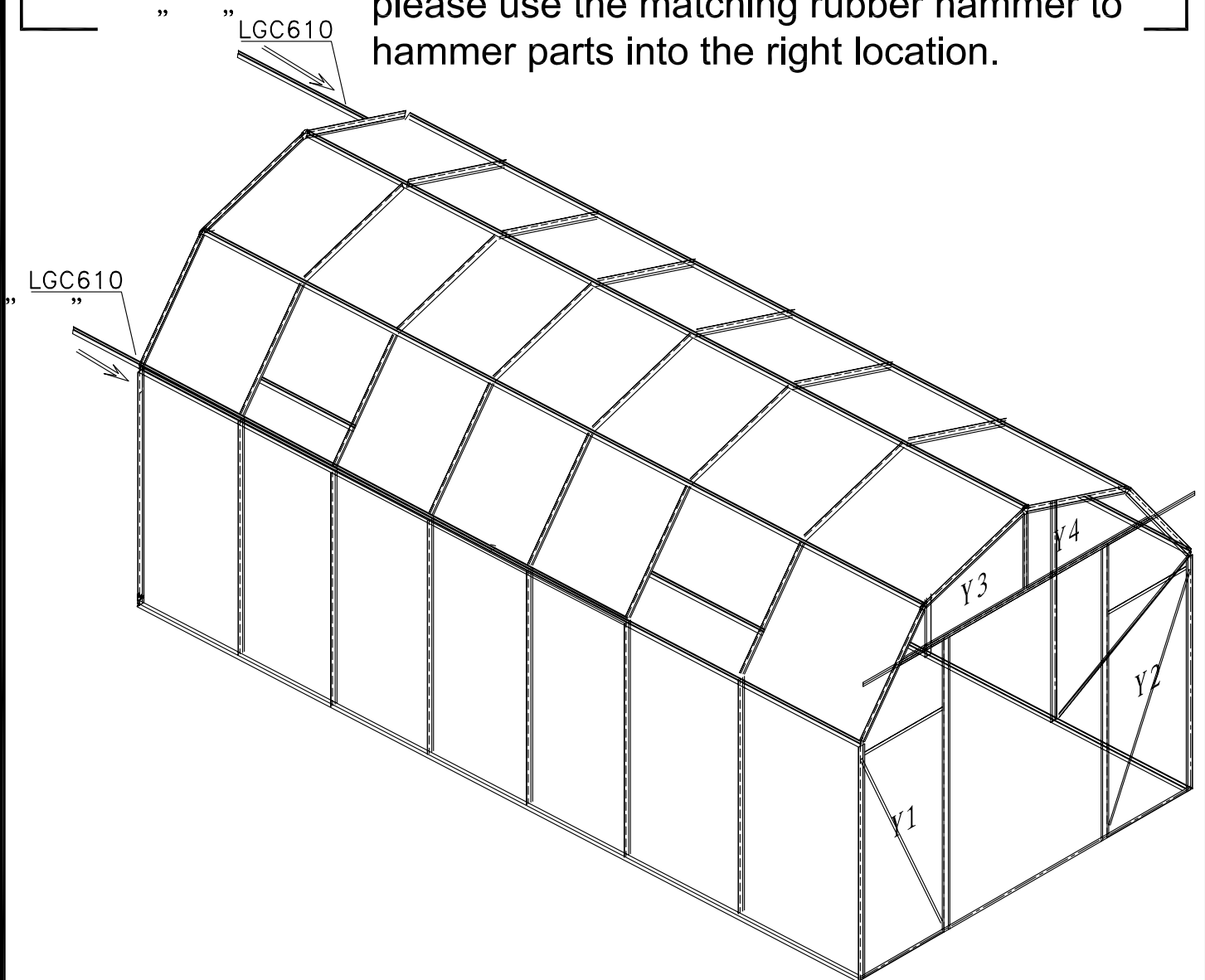

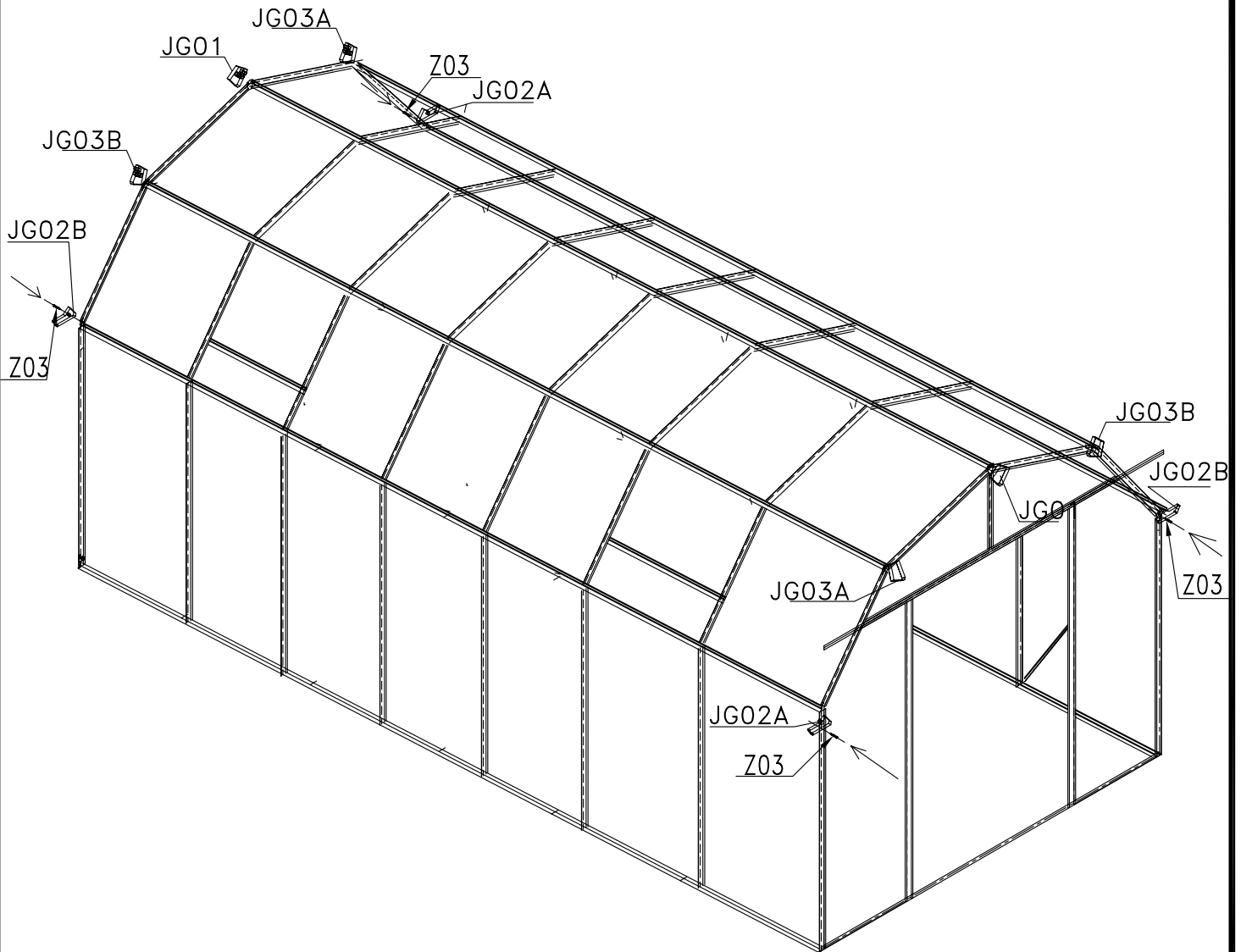

When installing JG01 & JG02 & JG03 (Plastic fittings), please cut down the sharp corner of the PC board if necessary.

# Door assembly drawing

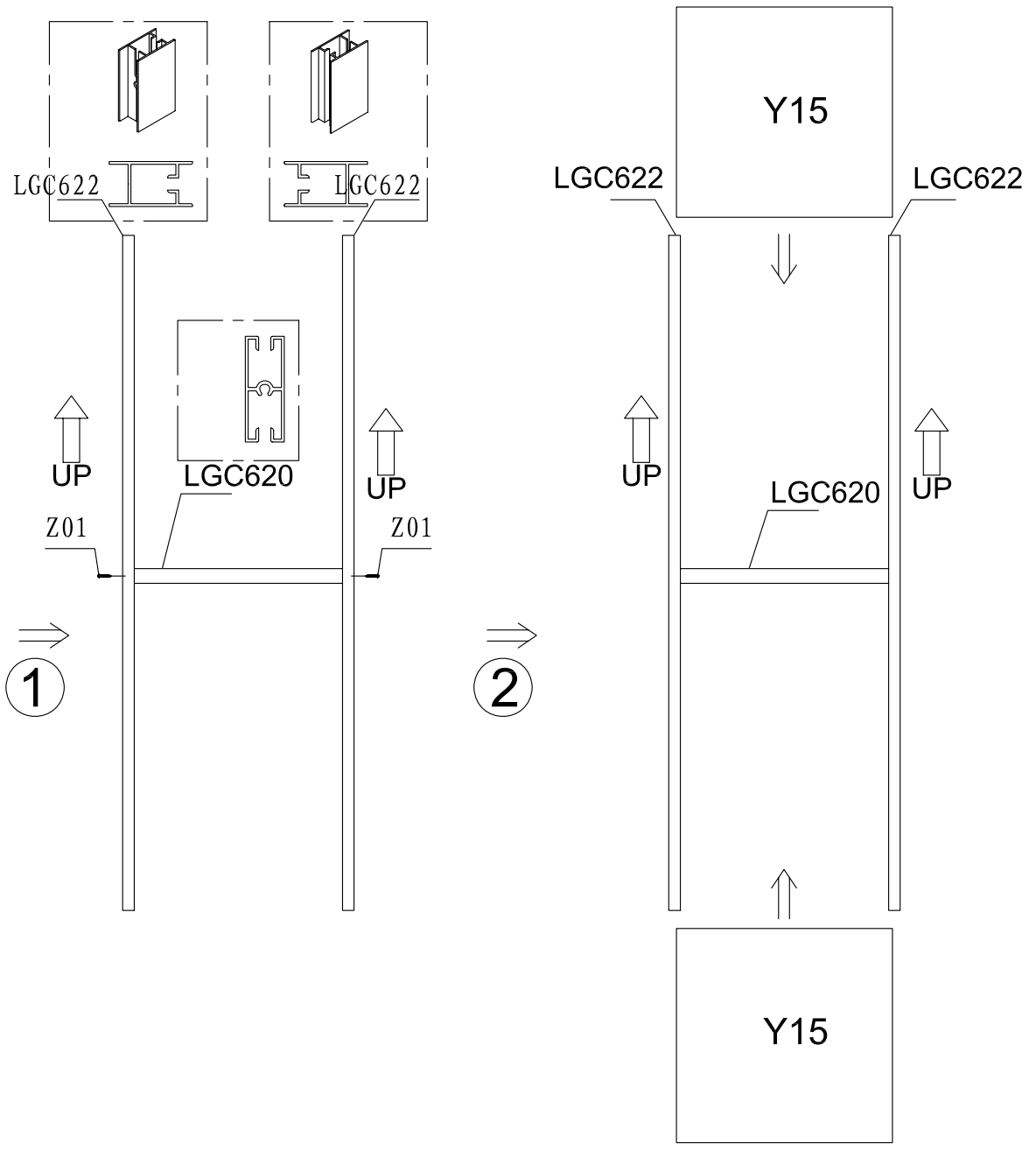

# Door assembly drawing

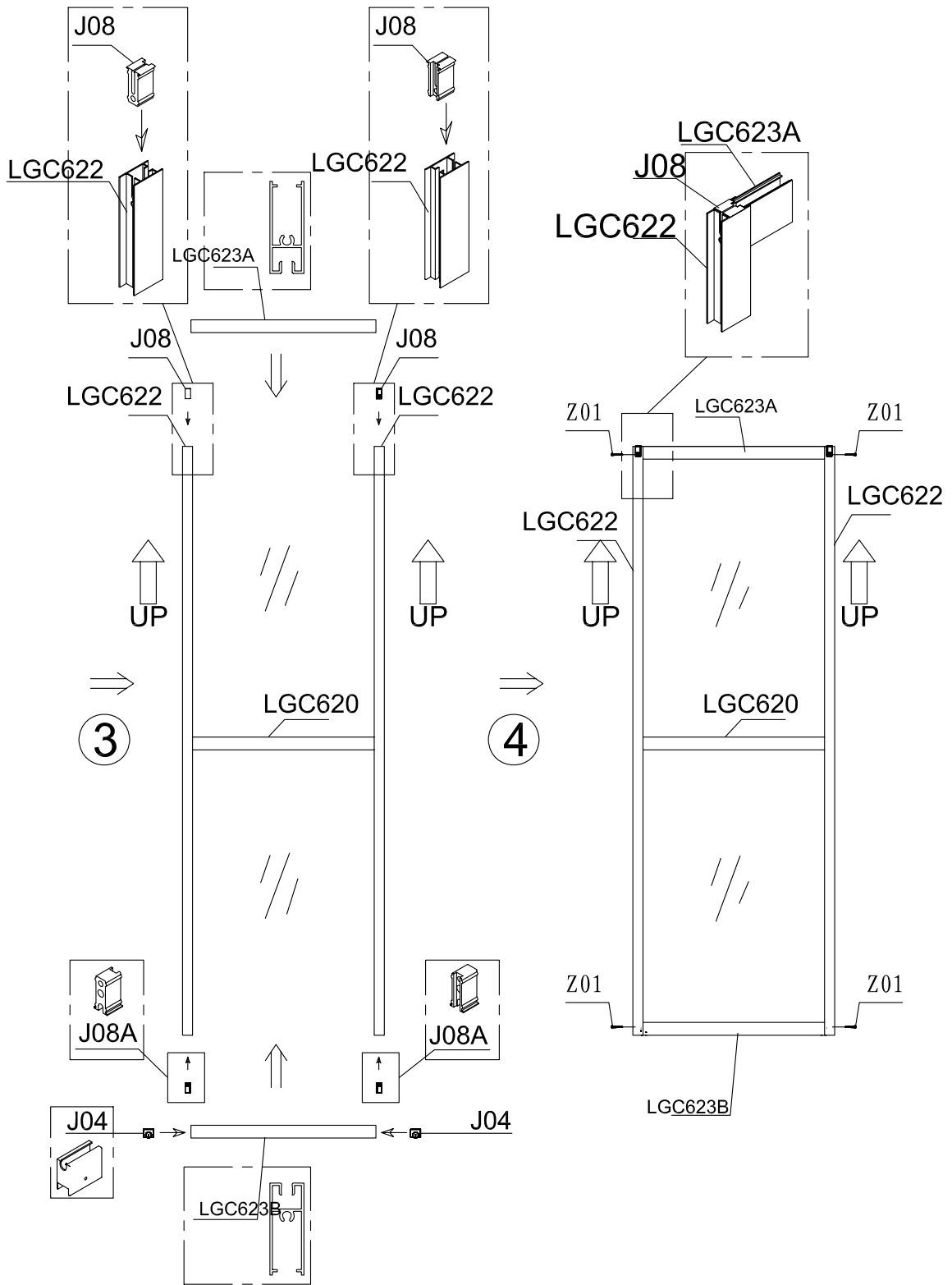

# Door assembly drawing

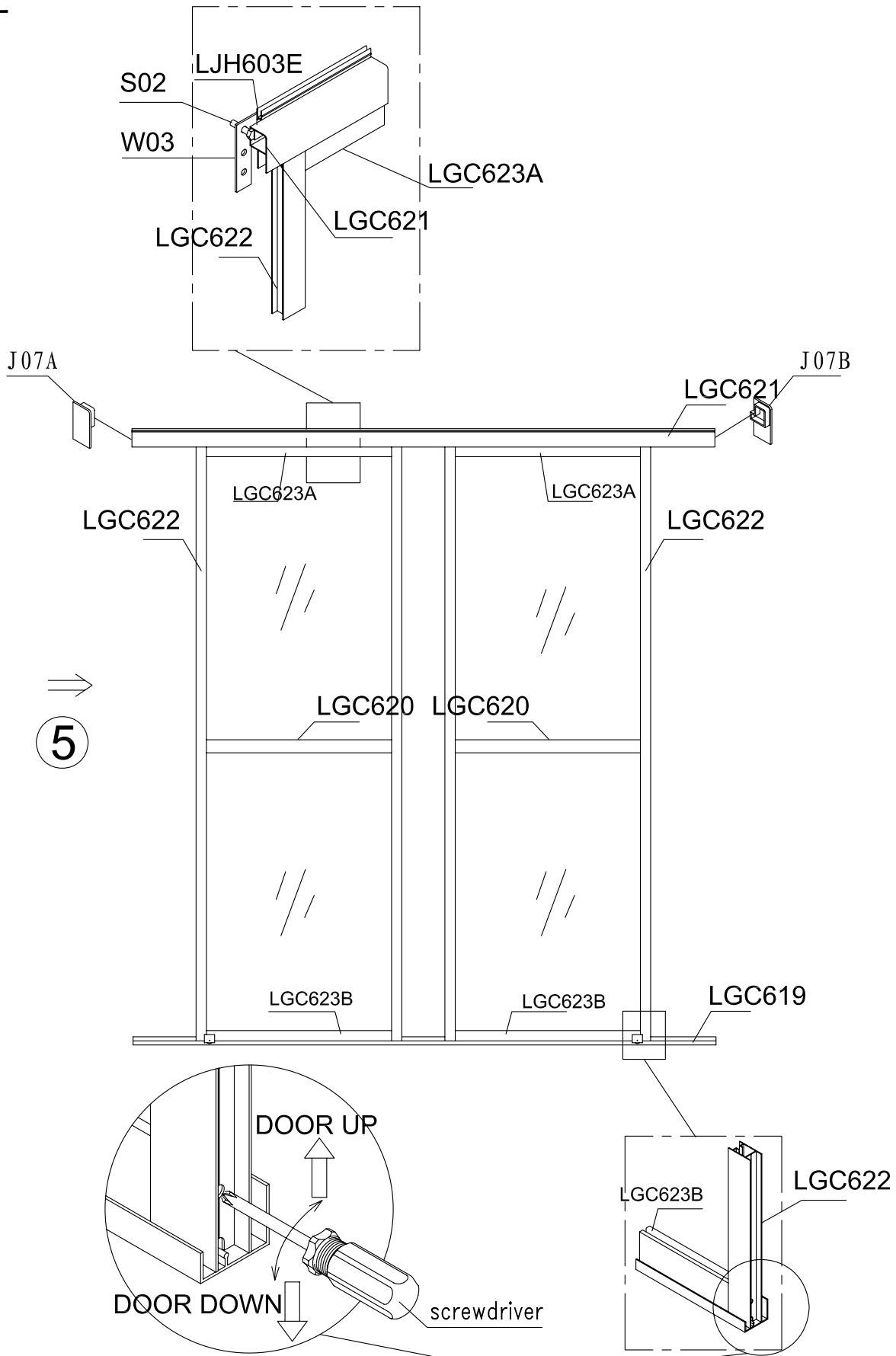

# BASE ASSEMBLY

Remark: No need cut down WG06 & WG07, its assembly direction can be changed per the actual condition, for example: It can be upturned for indoor hard floor or insert WG06 feet into outdoor ground like the drawing showed.

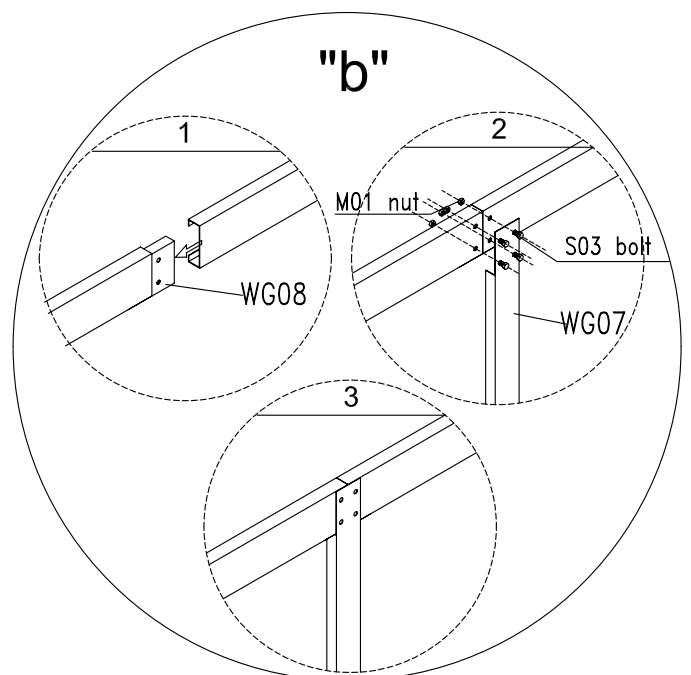
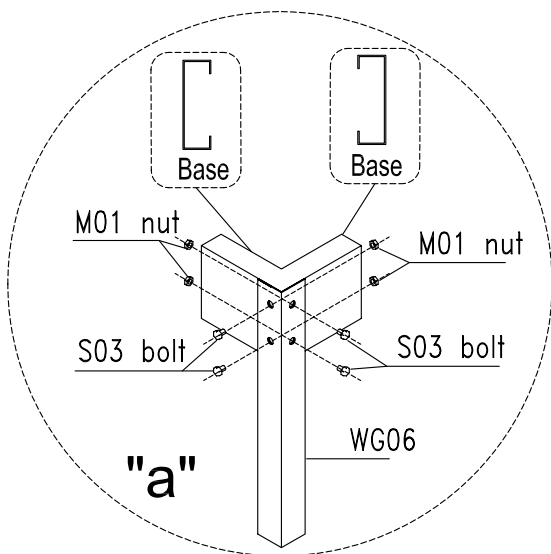
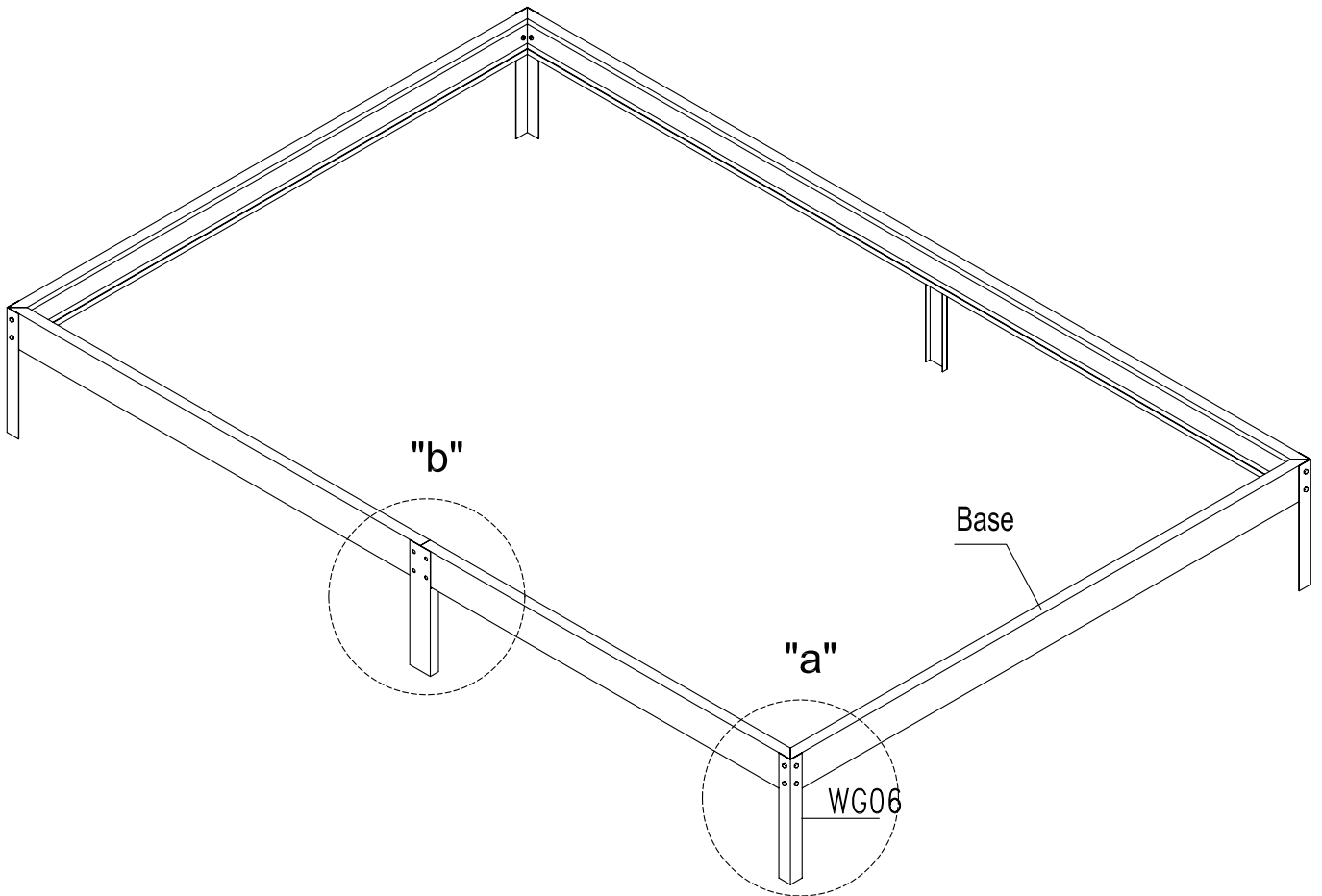

30

After inserting the 4pcs WG06 & 2pcs WG07 into ground for fastening the base well, put completed house on the base.

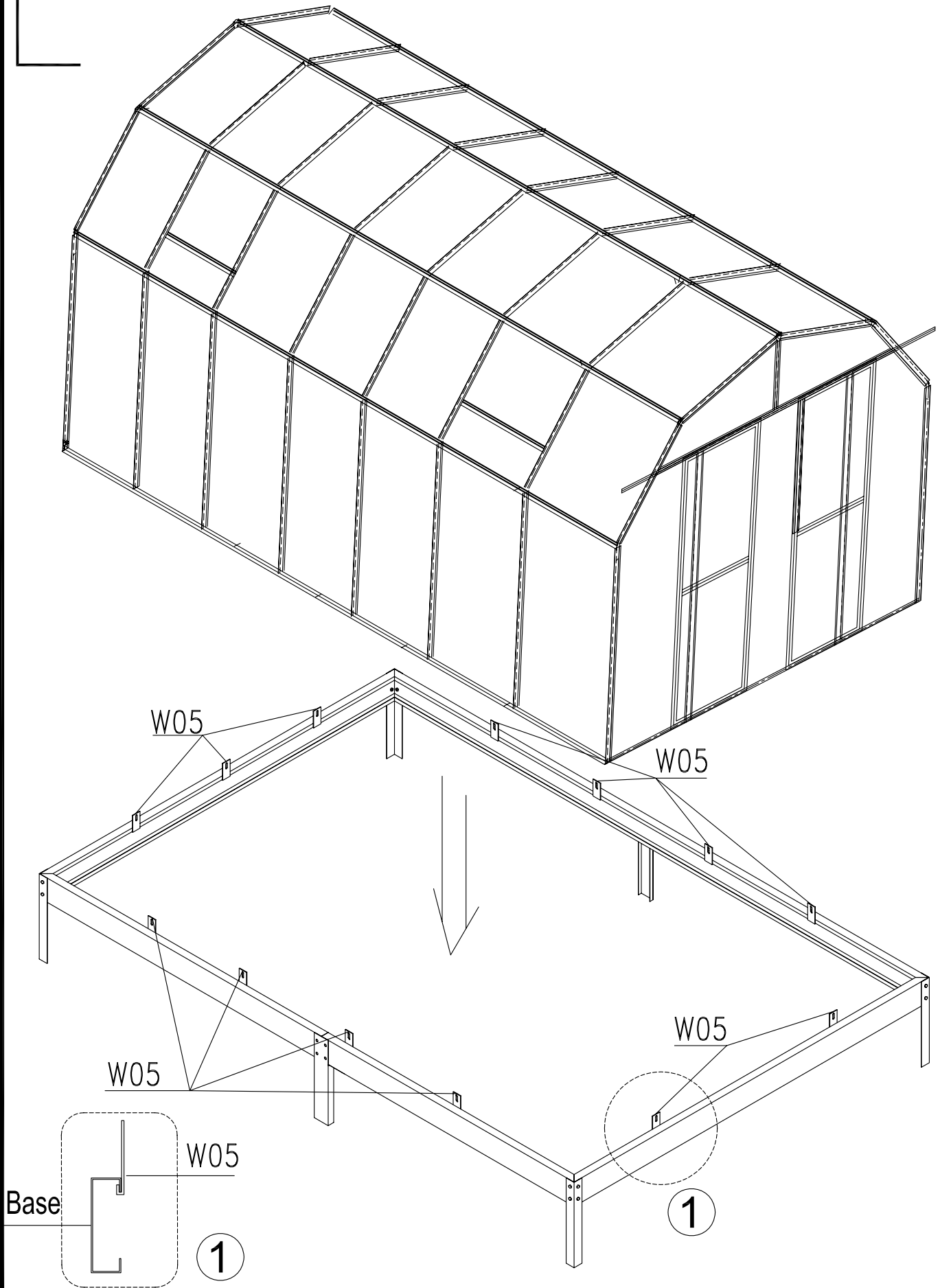

31

1. Galvanized steel base is for fastening the greenhouse, greenhouse with the base is surely better than the one without the base.
2. Please dig four holes for inserting the base feet on the ground.
3. If you are in windy weather, please dig the holes deeper and insert the base feet into the ground with concrete, so it can make the greenhouse more stable to resist against the storm.

